

### Strike Dimensions

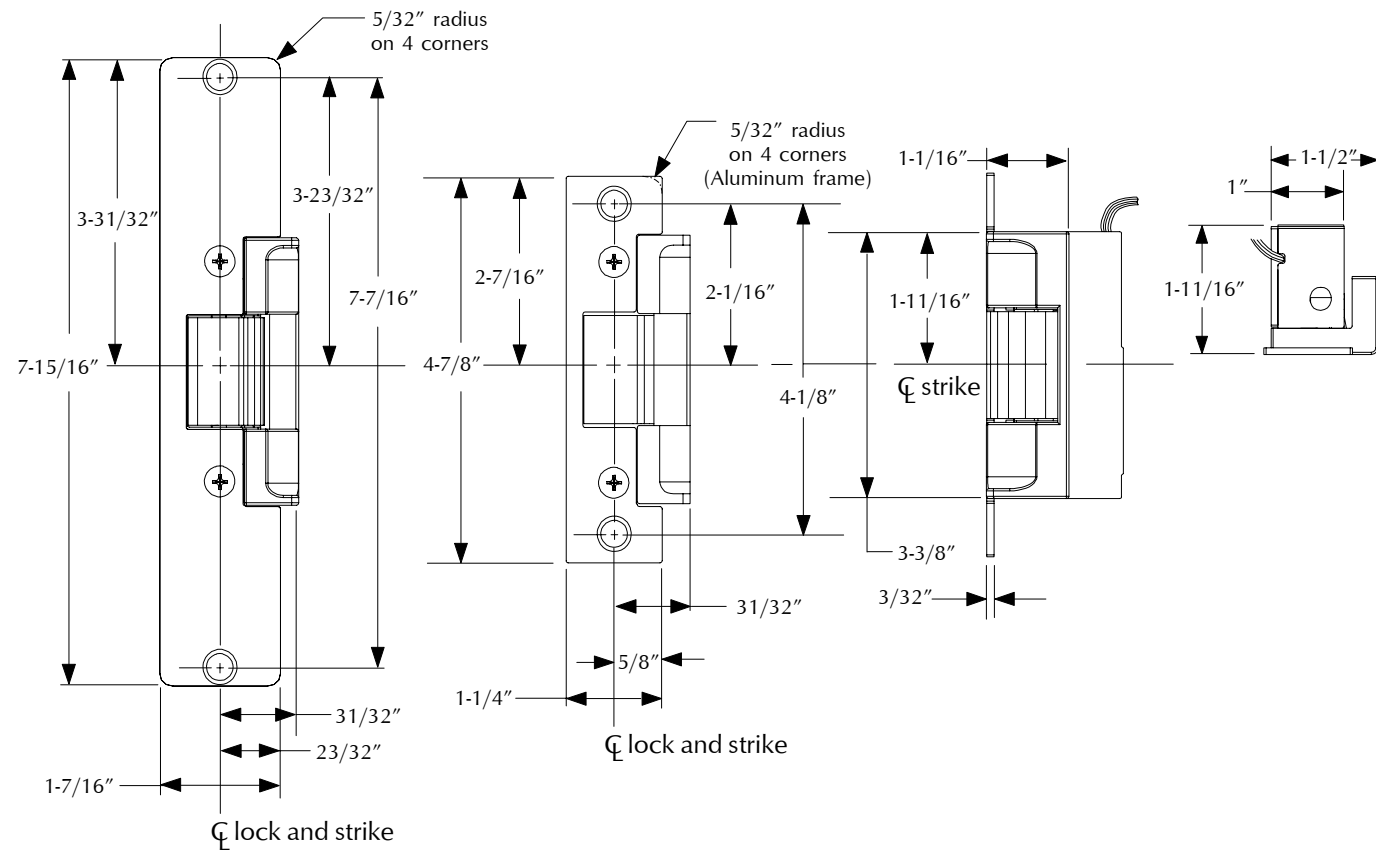

### Short Faceplate Suggested Cut-out

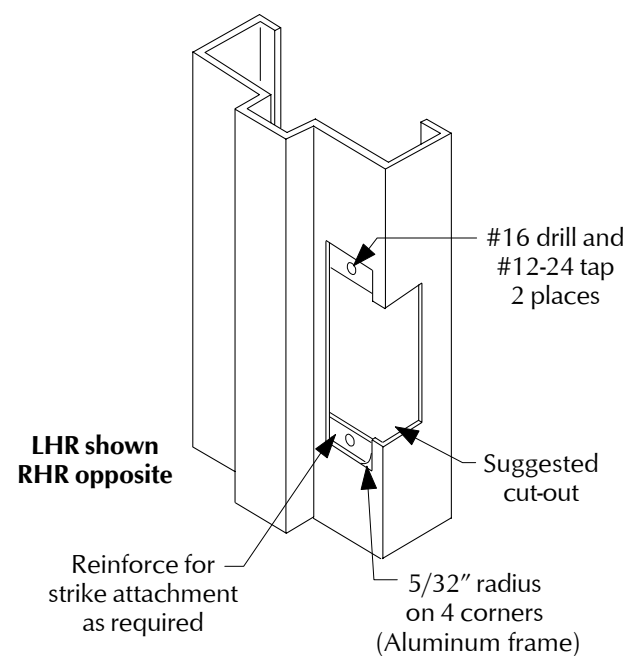

### Long Faceplate Suggested Cut-out

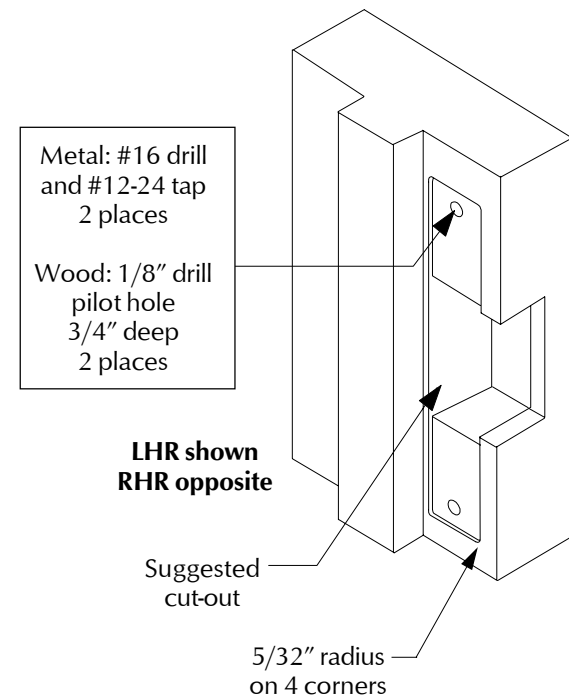

# VON DUPRIN® Installation Instructions



931029-00

## 5100 Electric Strike

1. For lock preparation, see lock instructions.
2. Install correct faceplate onto strike (Figure 1).

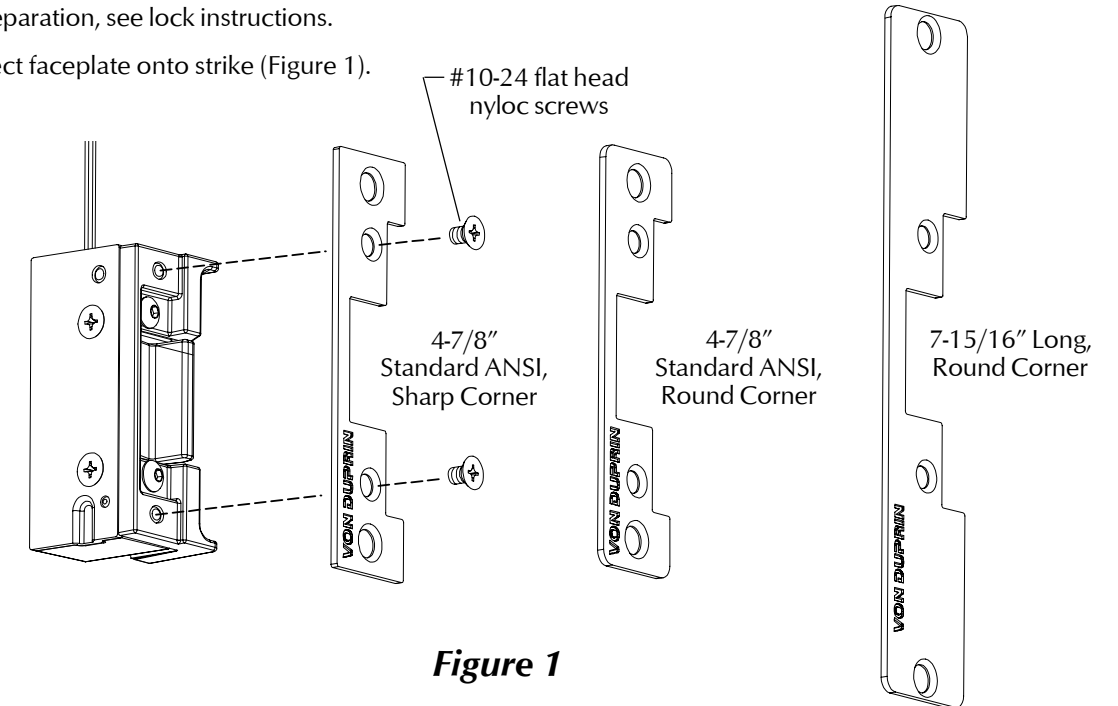

Figure 1

3. Prepare frame for strike (see page 4 for dimensions).  
Note: Prepare room for RCP rectifier if needed.
4. Make sure strike operates in correct mode. Lip of fail-safe (FS) strike can be moved when strike is not powered. Lip of fail-secure (FSE) strike cannot be moved when strike is not powered. If necessary, remove backbox cover (Figure 2) and change strike mode by repositioning actuator (Figure 3).

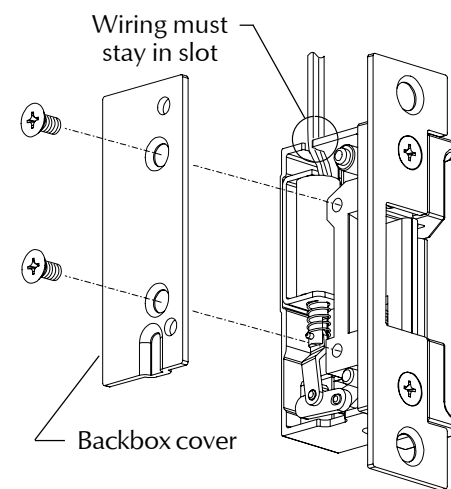

Figure 2

**NOTE**  
When using the electric strike in fail-secure mode, the local authority having jurisdiction shall be consulted to assure compliance in allowing emergency exit from the secured area.

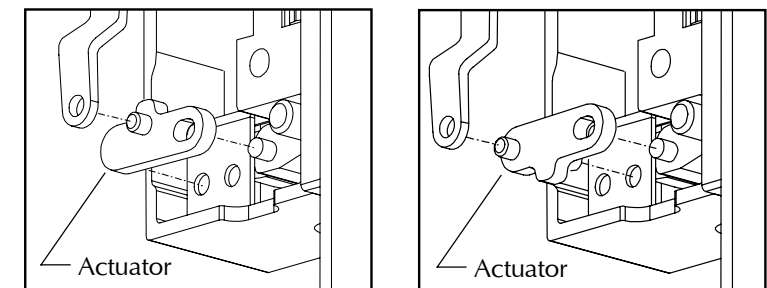

Figure 3

- Check power source voltage (12 or 24 VAC or VDC).
- When using 12 VAC or 24 VAC power, install SO kit to convert AC power to DC (Figure 4).
- Wire strike solenoid for proper voltage (Figure 5). **Caution: Do not connect 24 VDC to 12 VDC configured strike.**

For DC operation, Von Duprin PS 861 and Locknetics 593 DC series power supplies are recommended.

SOLENOID POWER REQUIREMENTS	
12 VDC, 0.38 A	
24 VDC, 0.19 A	

For AC operation, Von Duprin SO-12 or 24 AC/DC convertor kit (shown below) is recommended.

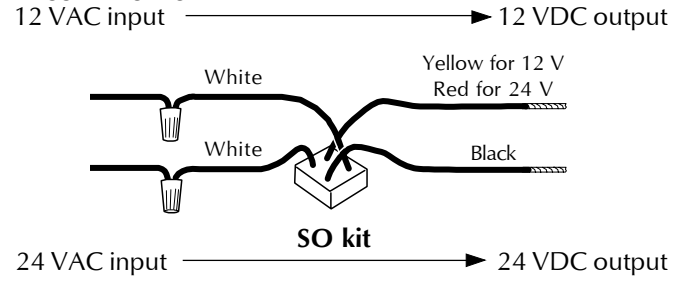

Figure 4

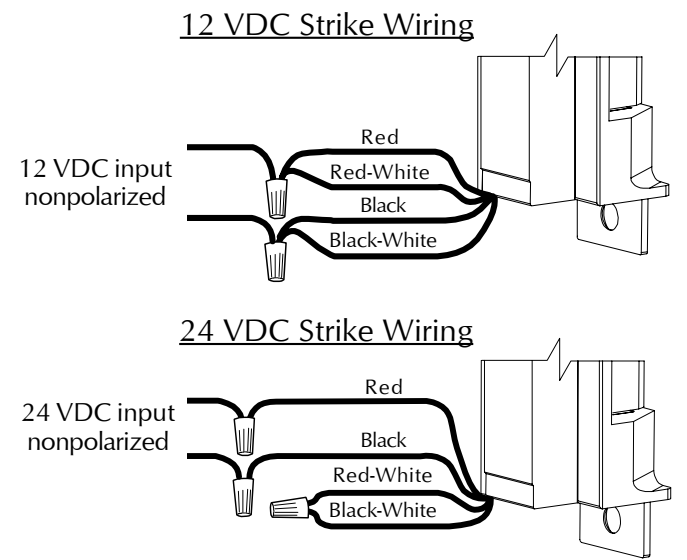

Figure 5

- Test strike: Apply solenoid power. Fail secure (FSE) lip unlocks. Fail safe (FS) lip locks.
- If cut-out for strike is too large along edge (Figure 6), cut neoprene filler and stick onto strike as shown (Figure 7). Note: This could occur in some retrofit applications.

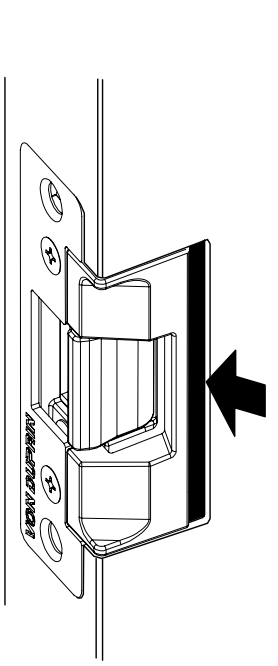

Figure 6

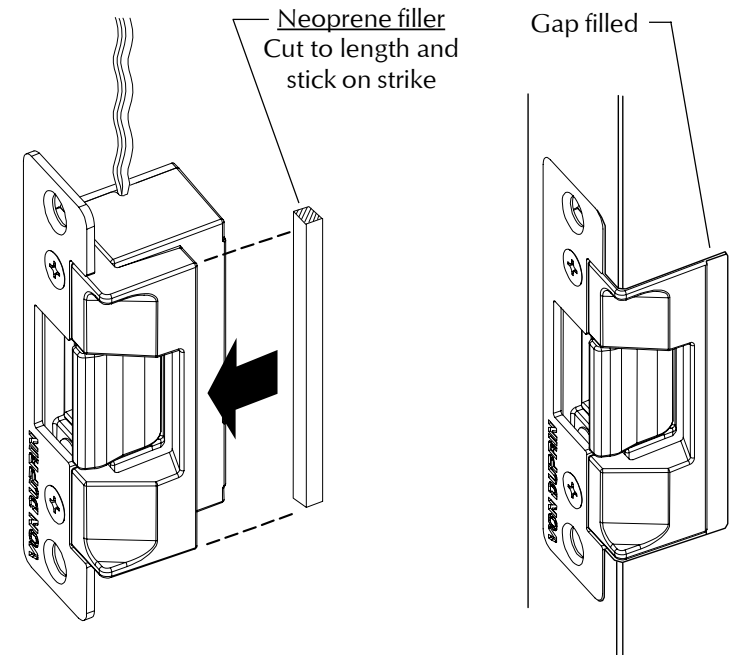

Figure 7

- If frame does not have built in mounting tabs, install mounting tabs supplied with strike as shown below (Figure 8).

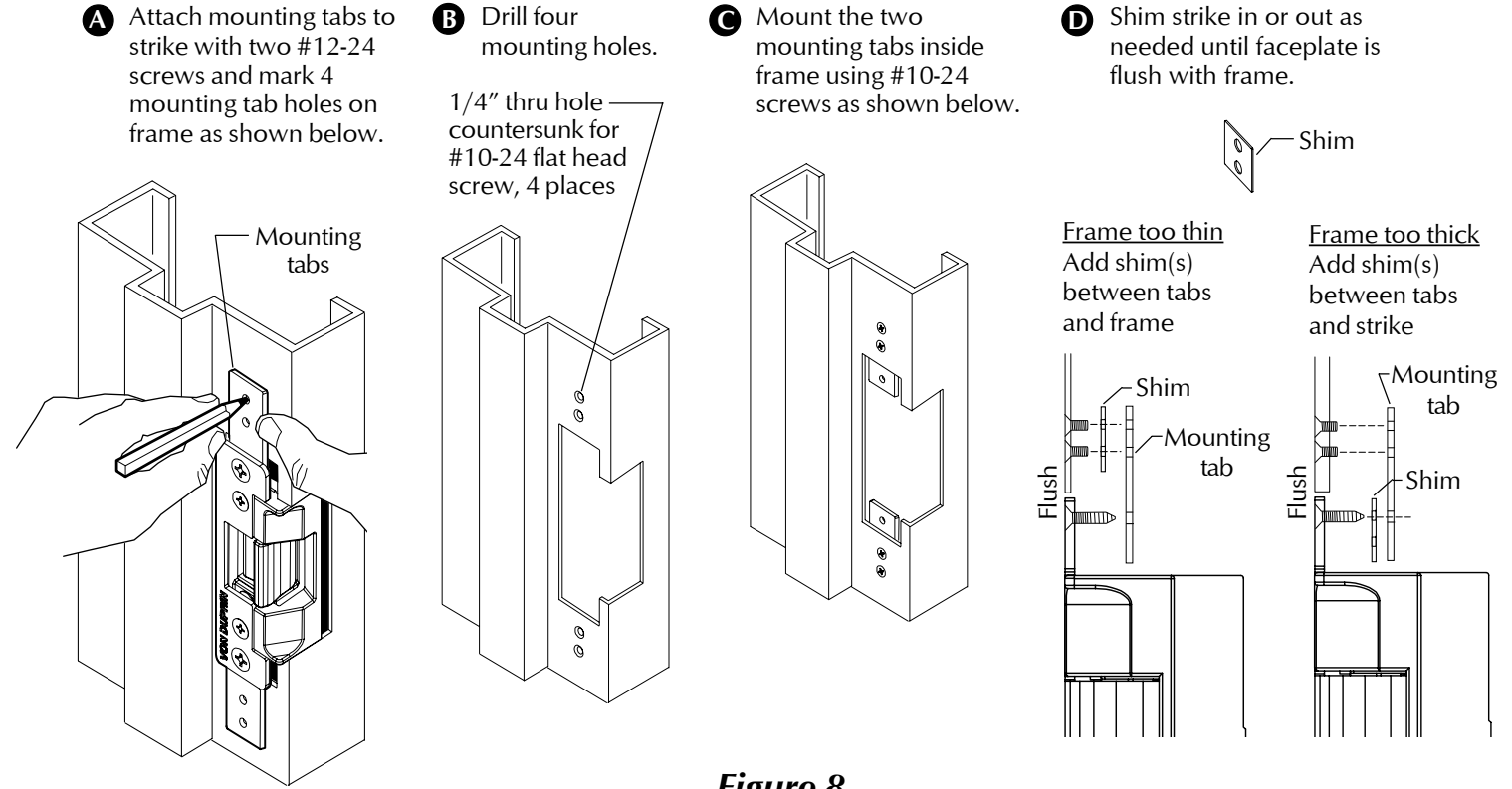

Figure 8

- Install strike with two #12-24 mounting screws. Make sure clearance between latch bolt and strike lip is 1/32" (Figure 9). If not, remove strike, adjust (Figure 10), and reinstall.

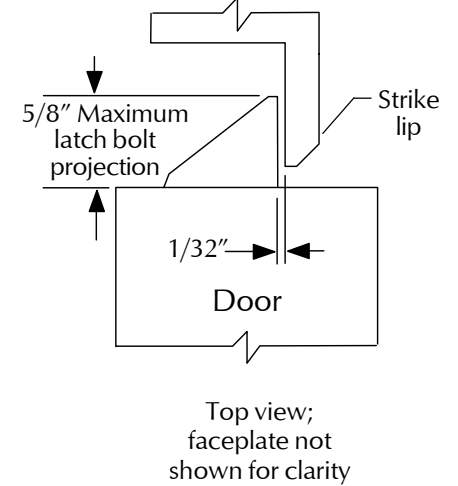

Figure 9

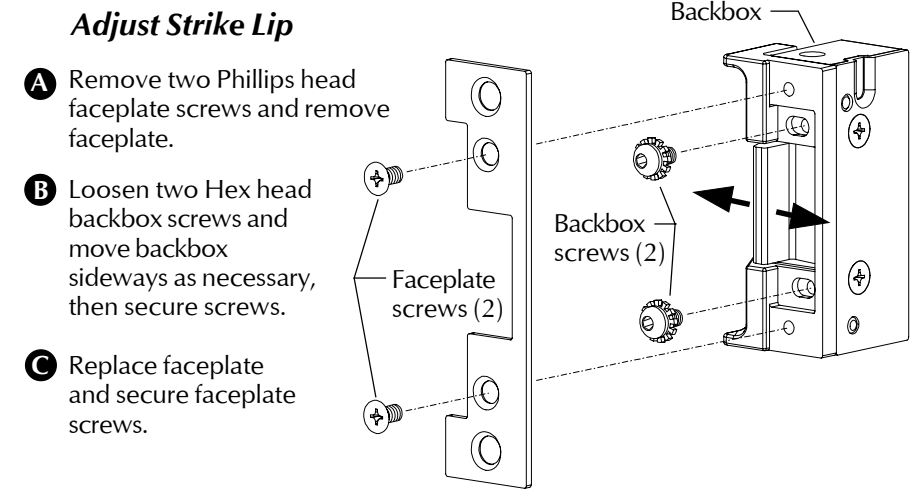

Figure 10

- Test door: With strike unlocked, door opens with latch bolt extended. When door closes, latch bolt rides over strike lip and relates.