

# INSTALLATION DIRECTIONS

## BEFORE APPLYING THIS DEVICE

- A. Threshold (if any) must be installed.
- B. Doors must be fitted and hung.
- C. Check that handing of hardware corresponds with handing of door.

## 1. APPLY STRIKE

- A. Tape appropriate strike template to stop.
- B. When Von Duprin Mullion is used apply strike at tapped holes in Mullion. (See illustration 1 or 2)
- C. Vertical rod and rim devices on pairs of doors require 1609J strike. See template No. 30021 for this application.

## 2. PREPARE DOOR

- A. Tape full size template No. 1 or 2, depending on handing of door, to inside face of lock stile. See Device Height Schedule.

**NOTE** BE SURE CENTERLINE OF LOCK STILE CASE IS PARALLEL TO STOP AND THAT EDGE OF CASE IS 3/16 FROM EDGE OF STRIKE. STRIKE MUST BE SHIMMED OUT IF LOCK CASE IS MOUNTED MORE THAN 3/16 FROM STRIKE.

- B. Prepare door as shown. See Fig. 1 for wood door application, and Fig. 2 for metal door application.

## 3. APPLY OUTSIDE TRIM IF REQUIRED

- A. See directions in trim carton. Line "X-X" on trim template corresponds to line "X-X" on device template and is parallel to edge of door. Transfer line "X-X" from inside face to outside face of door.
- B. Prepare outside face of lock stile.
- C. Cut off cylinder tailpiece, if necessary, to extend 5/8 to 3/4 thru door and into device case.
- D. Apply outside trim.

## 4. INSTALL LEVER ARMS

- A. Insert lever arms into lock stile and hinge stile cases.
- B. Assemble axles and tighten securely. (See instructions in axle envelope.)

## 5. APPLY LOCK STILE CASE

- A. Remove key from cylinder.
- B. Attach lock stile case to door. (See Fig. 1 or Fig. 2)
- C. Test key action.

## 6. APPLY HINGE STILE CASE AND CROSSBAR TUBE (FIG. 4)

- A. Dog lever arms in depressed position.
- B. Slip crossbar tube on lock stile and hinge stile lever arms. (See Direction Sheet 41009 for cutting crossbar, if necessary)
- C. Be sure crossbar is level and hinge stile case is parallel to edge of door and approximately on centerline of exposed stile.
- D. Using holes in hinge stile case, mark location and prepare door for attaching screws.
- E. Apply hinge stile case with crossbar in place.
- F. Tighten wedge-lite set screws securely with dog key and screwdriver or equivalent for leverage, and test crossbar for free action. (See Direction Sheet 41009 for these instructions.)

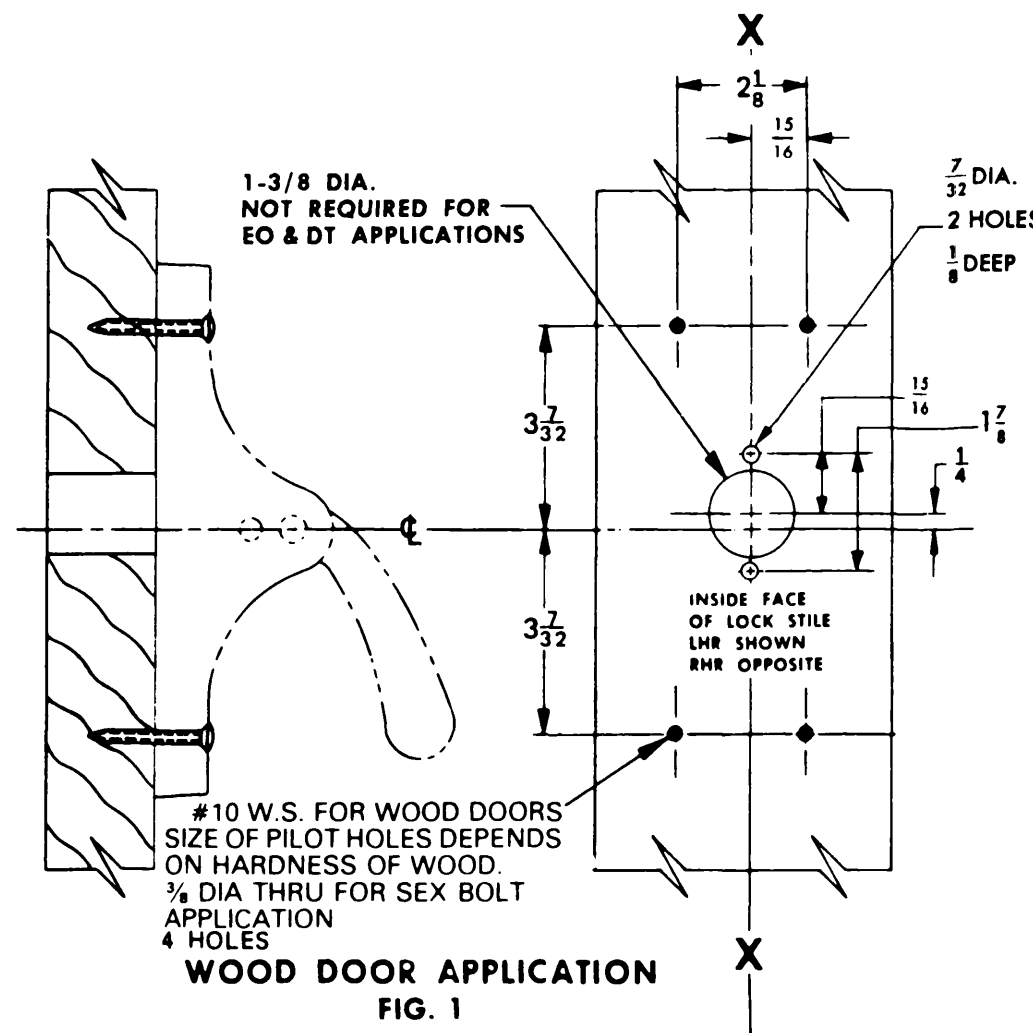

**WOOD DOOR APPLICATION**  
FIG. 1

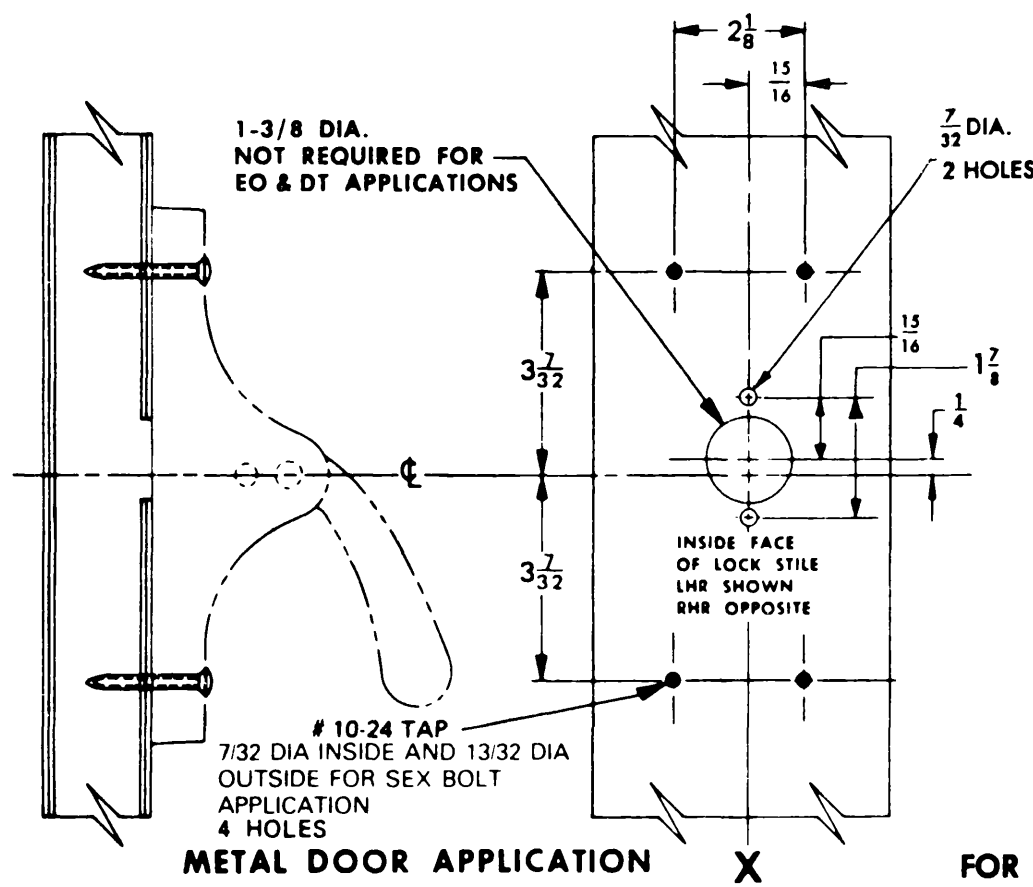

**METAL DOOR APPLICATION**  
FIG. 2

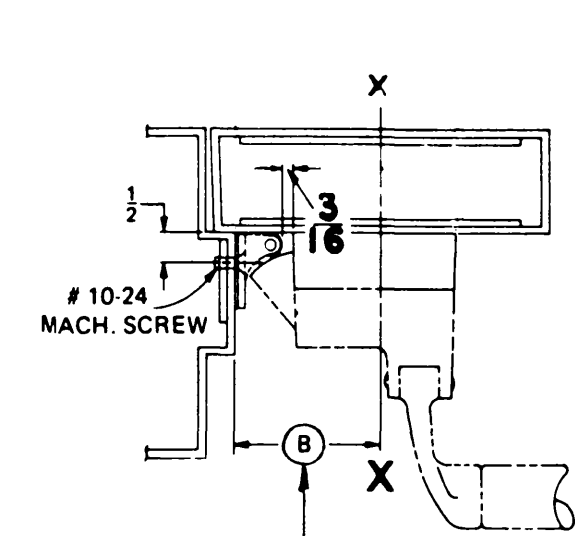

STRIKE	DIMENSION (B)	MIN. STILE
299(Shown)	2-1/2	4-3/8
264	2-1/4	4-1/8
1606	2-1/16	3-15/16

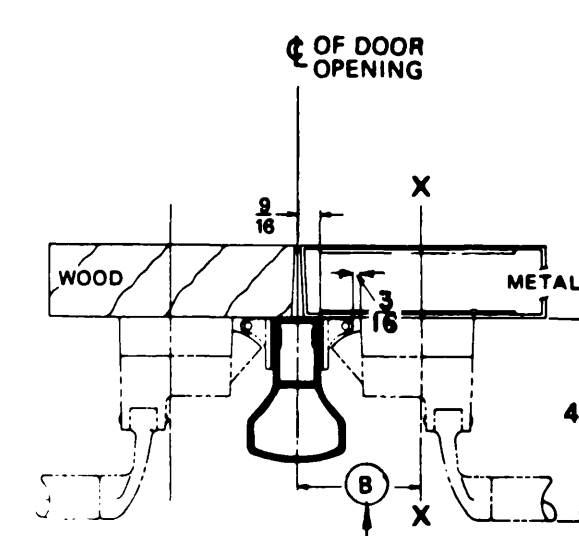

MULLION & STRIKE	DIMENSION (B)	MIN. STILE
4954x299(Shown)	3-1/2	4-11/16
4654 x 264	3-1/4	4-7/16
5254/5654 x 264	2-13/16	4"

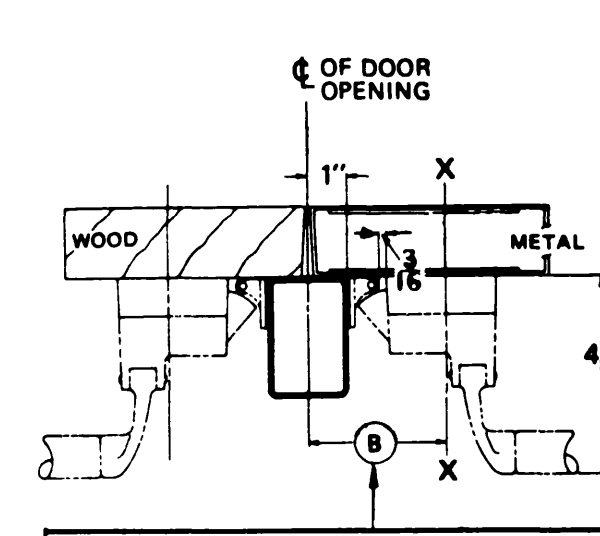

MULLION & STRIKE	DIMENSION (B)	MIN. STILE
4954x299(Shown)	3-1/2	4-11/16
4654 x 264	3-1/4	4-7/16
1654 x 1606	3-1/16	4-1/4

ILLUST. 1

ILLUST. 2

SINGLE DOOR OPENING  
39-13/16 TO FINISHED FLOOR

DOUBLE DOOR OPENING  
WITH VON DUPRIN MULLION  
AND THRESHOLD

THRESHOLD NO.	TO FIN. FLOOR
ALL THRESHOLDS	39-11/16
NO THRESHOLD (FLAT SILL)	39-11/16

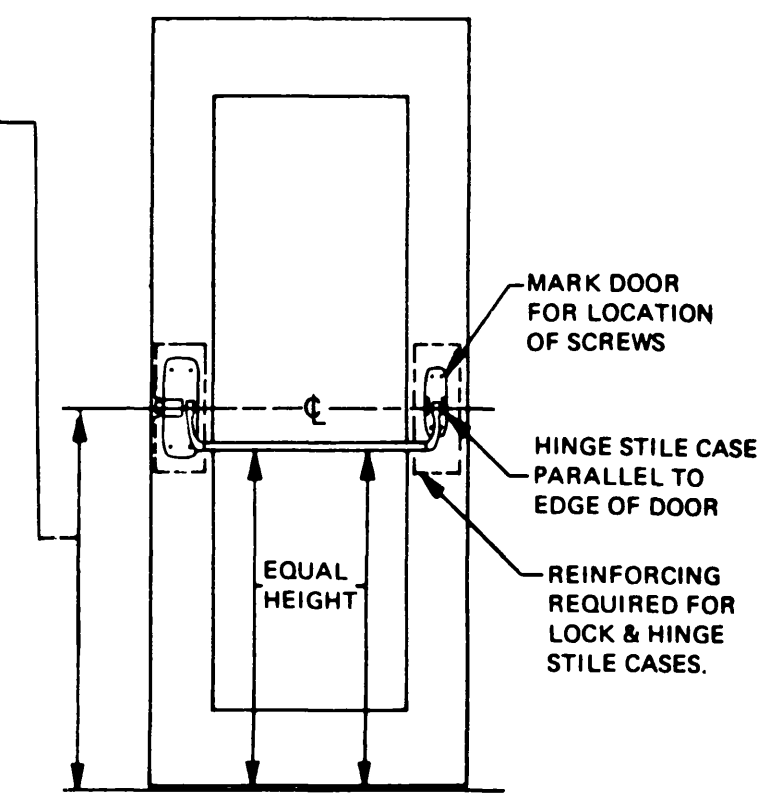
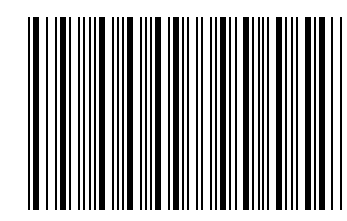

FIG. 4



911156-00

DESCRIPTION  
880EO, 88DT & 88NL SERIES RIM DEVICE

**VON DUPRIN**  
DIRECTION NUMBER 911156-00(15) DATE 1/01/03

FOR TRIM APPLICATION SEE DIRECTIONS  
IN TRIM CARTON IF REQUIRED

VON DUPRIN®

