

9

Slide mechanism case forward and install new XP bracket.

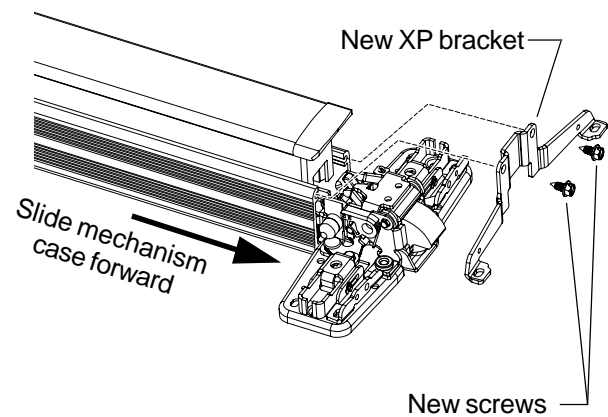

10

Check latch function as shown.

A. Depress auxiliary bolt and check latch bolt. Latch bolt should be locked and will not move while auxiliary bolt is depressed.

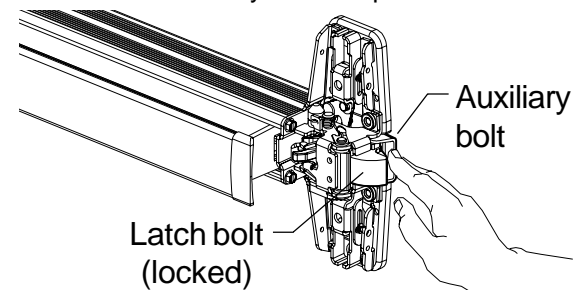

B. With auxiliary bolt still depressed, press and hold device push bar. Press latch bolt from top and bottom. It should depress freely in both directions.

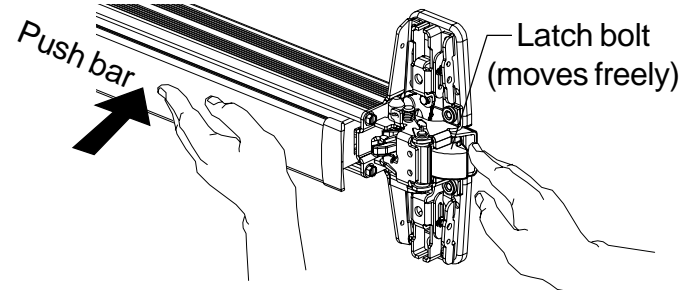

11

Install tailpiece guide, if necessary, and reinstall device.

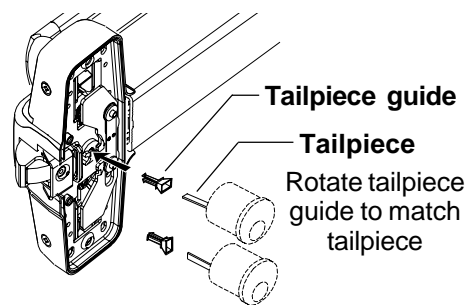

Note: Reconnect device wiring, if necessary.

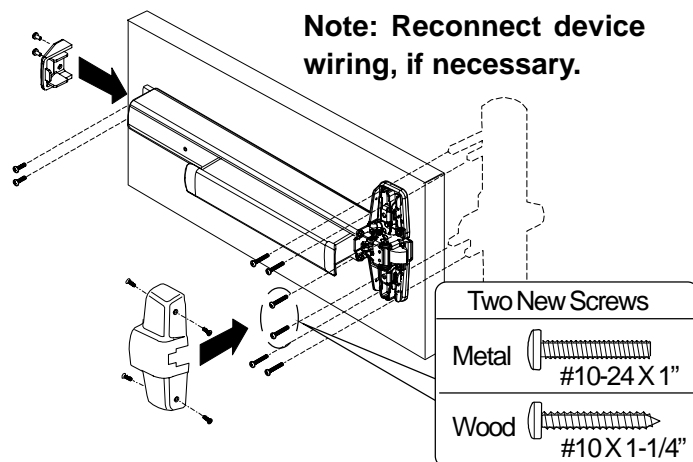

12

IMPORTANT! Perform operational check.

A. With door closed, push against door without touching device. Device should NOT allow door to open.

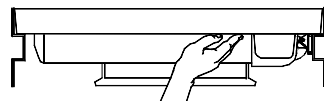

B. With door closed, push device push bar. Device should allow door to open.

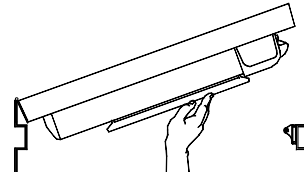

C. If device does not function as described, adjust strike position and continue operational check until device functions as described above.

D. If using 954 strike, install 2 additional screws to lock down strike.

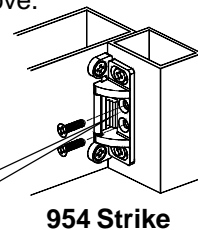

#7 Drill, 1/4"-20 tap, 2 places

VON DUPRIN® Installation Instructions



911001-00



XP98/XP99 Center Case Retrofit

⚠ WARNING

If exit device has a push bar with rivets, as shown below, this XP center case kit CANNOT be used.

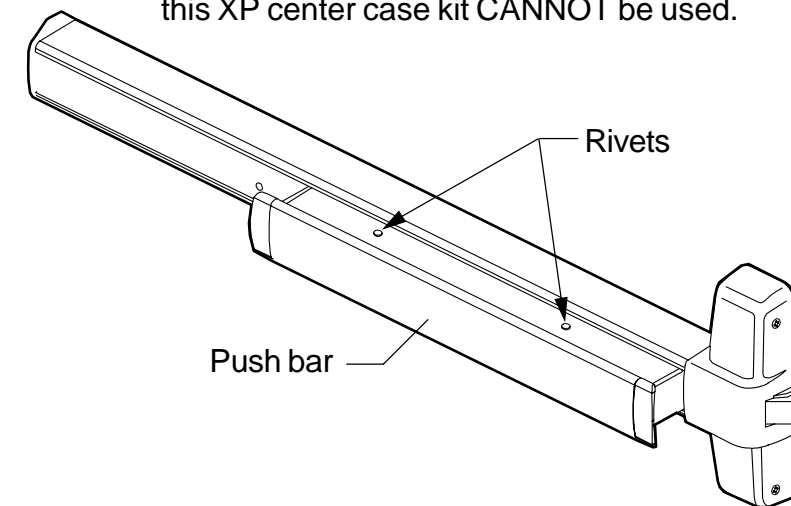

The parts shown below are included in this kit:

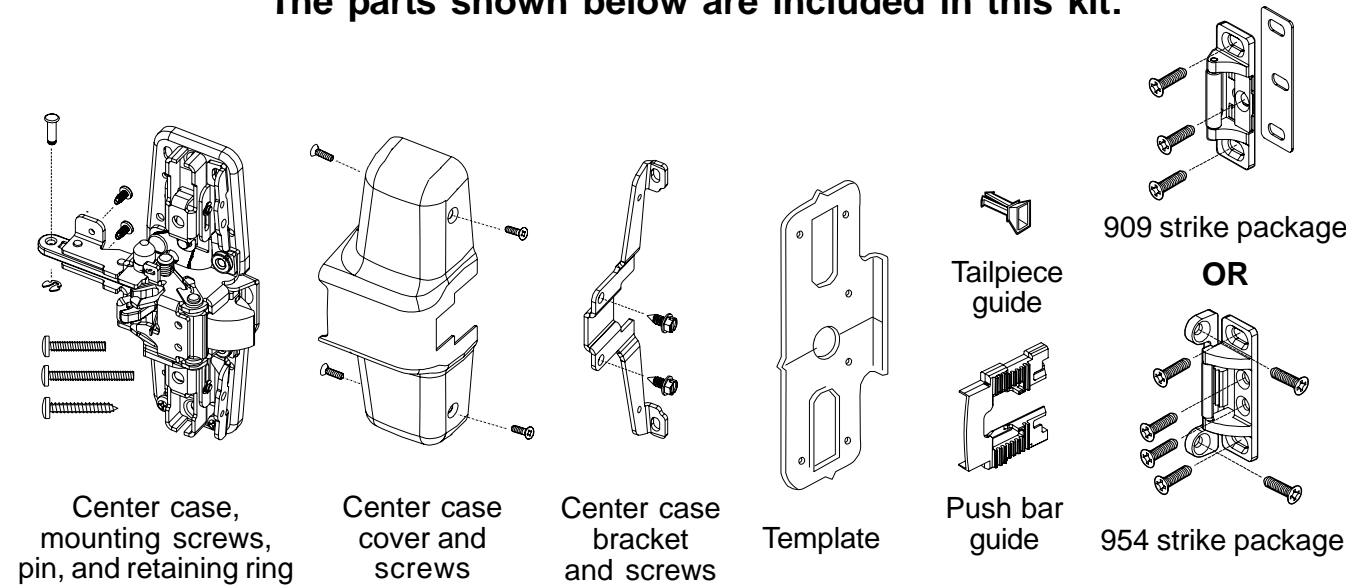

Website: www.vonduprin.com
Phone: 1-888-371-7331

911001_00(0) Copyright © 2006 Ingersoll-Rand Company Limited



1 Remove existing exit device and strike from door.

Note: Disconnect device wiring if necessary.

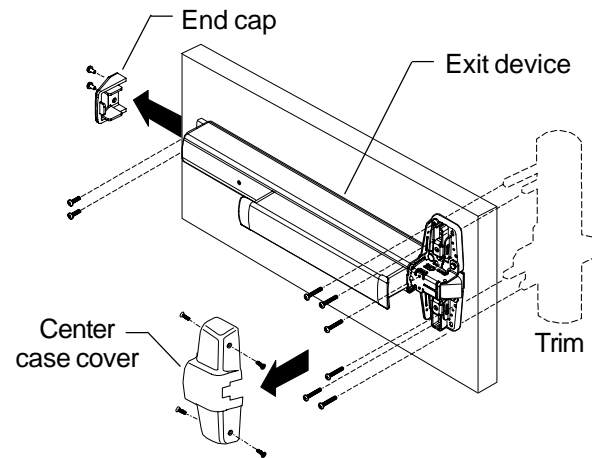

CAUTION

Old 299/299F or 499F strike cannot be used with XP98/99 device. Strike must be removed and replaced with new strike.

Old strike	Replace with
299/299F	909
499F	954

2 Install 909 strike. If 954 strike is being installed see step 3.

A. Re-drill and tap existing center strike hole for 1/4"-20.

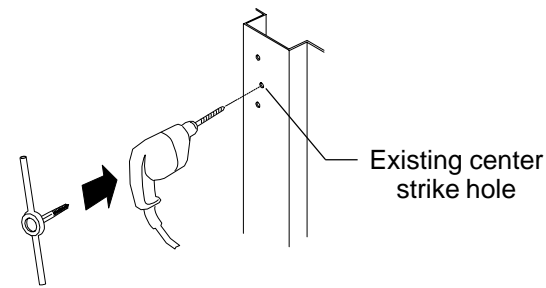

B. Position strike against door, then attach strike to frame with new center screw and locking plate.

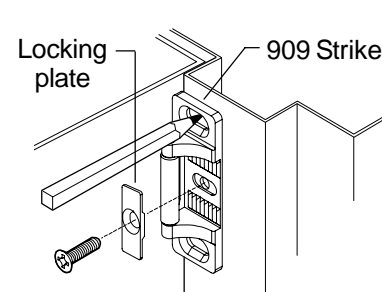

C. Mark and prepare 2 outer holes for 1/4"-20 and install screws.

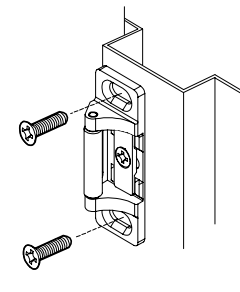

3 Install 954 strike, if necessary.

A. Re-drill and tap two existing strike holes for 1/4"-20.

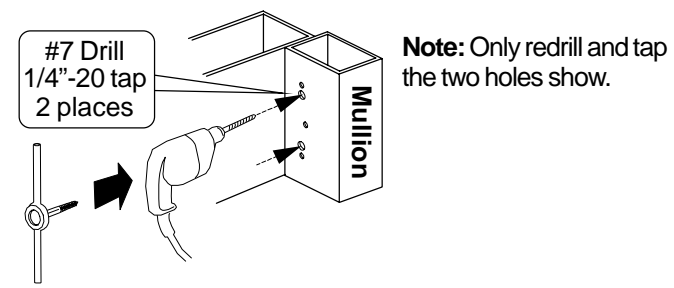

B. Align strike along dashed centerline (⌀) as shown. This represents the centerline of the strike. Prep two holes and install.

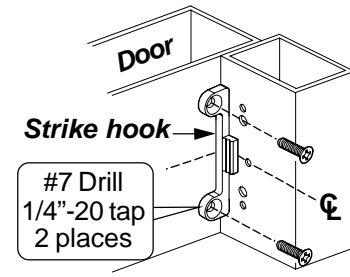

C. Attach strike with two screws through slots.

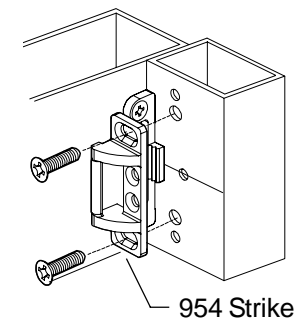

4 Remove old center case.

A. Remove old center case bracket.
B. Slide mechanism case back approximately 5".

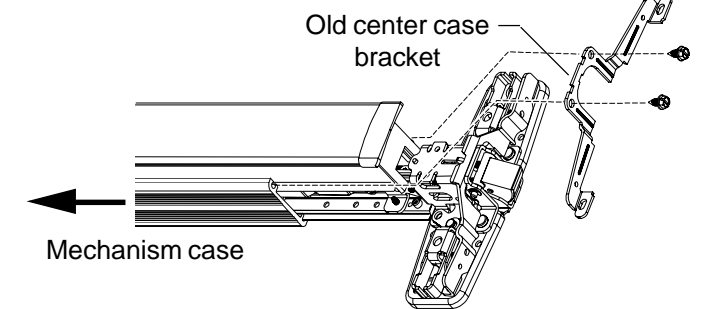

C. Remove retaining ring and pin, and two screws to remove old center case.

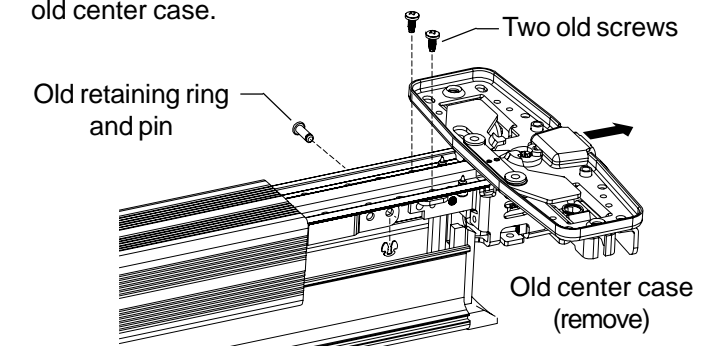

5 Match master cam function for new XP center case to that of removed center case.

Inspect underside of old center case for master cam.

If NL drive screw (shown below) has been removed, it must be removed from new XP center case as well.

If NL drive screw is present in old center case, leave NL drive screw in new XP center case.

Additionally, if NL drive screw is present in old centercase, handing of the lock slide must also be matched on the new XP center case.

To change handing of lock slide temporarily remove NL drive screw and rotate master cam until lock slide is in the same position as old center case (full up or full down).

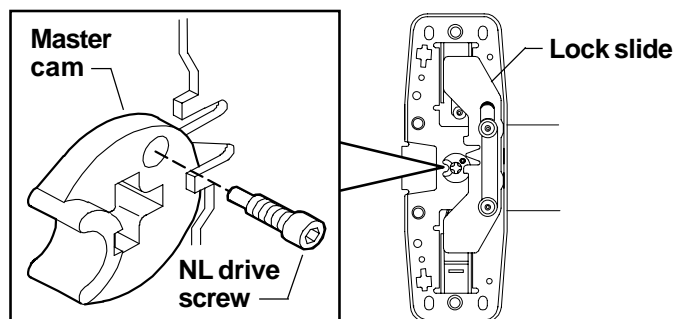

6 Drill and tap two new support holes in door.

A. Align plastic template with existing holes as shown.

B. Mark 2 new holes as shown.

C. Prepare 2 new holes per chart below:

	Metal	Wood
	#25 Drill	1/8" Drill
	#10-24 tap	pilot 1" deep

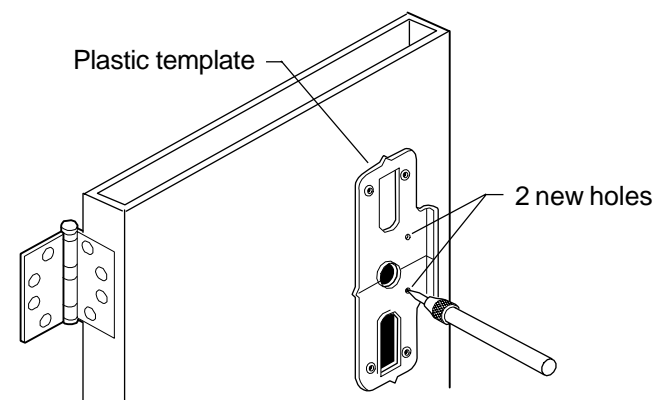

NOTE: If plastic template will not align correctly with the 4 outer holes, bolt new center case on door with the 4 screws and use it as a template to mark the 2 holes shown above.

7 Attach new XP center case to device as shown.

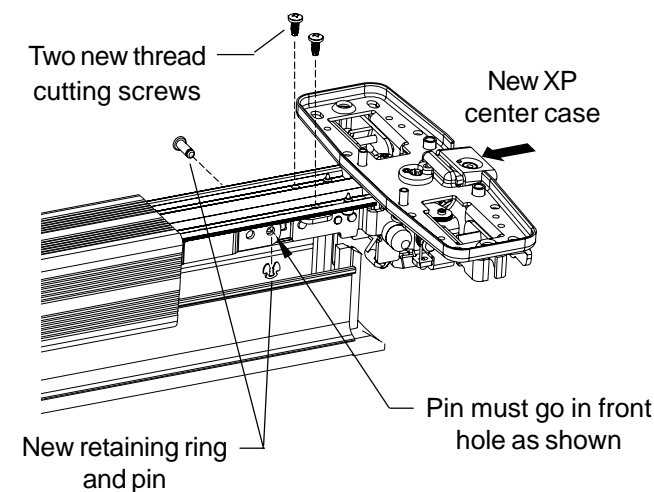

WARNING

New retaining ring and pin must be installed securely. If pin comes out, door will not open properly.

8 If device does not have plastic guide near center case, install plastic guide.

A. Slide mechanism case off baseplate assembly.
B. Lift push bar off baseplate assembly.
C. Install new plastic guide on push bar near center case.
D. Hold both plastic guides on push bar and reinstall push bar.
E. Slide mechanism case back onto baseplate assembly.
F. Verify that plastic guides stay on each end of pushbar.

