

CUT DEVICE

1 Measure amount to cut off device.

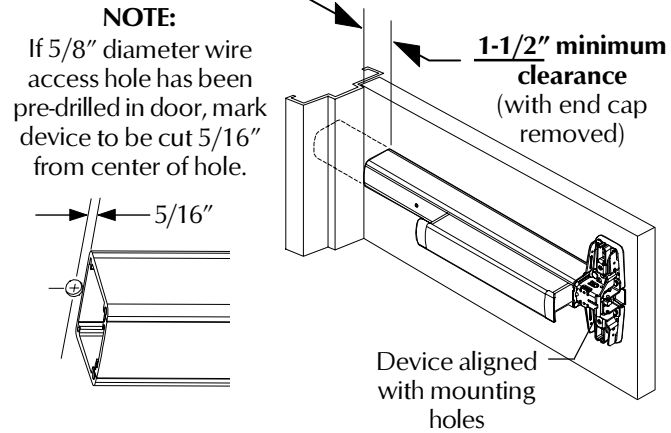

2 Tape and mark area being cut.

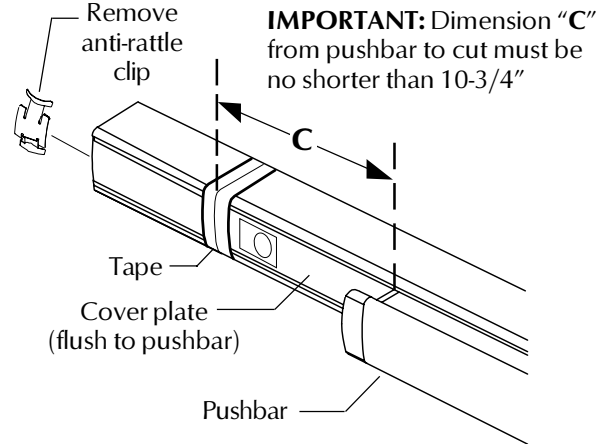

3 Cut device square.

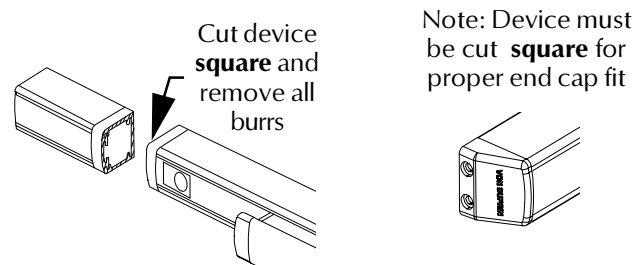

4 Slide anti-rattle clip into device.

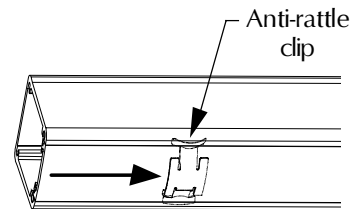

VON DUPRIN®

Installation Instructions

CX98/9975 Series Mortise Device

CHEXIT™ Controlled Exit Device

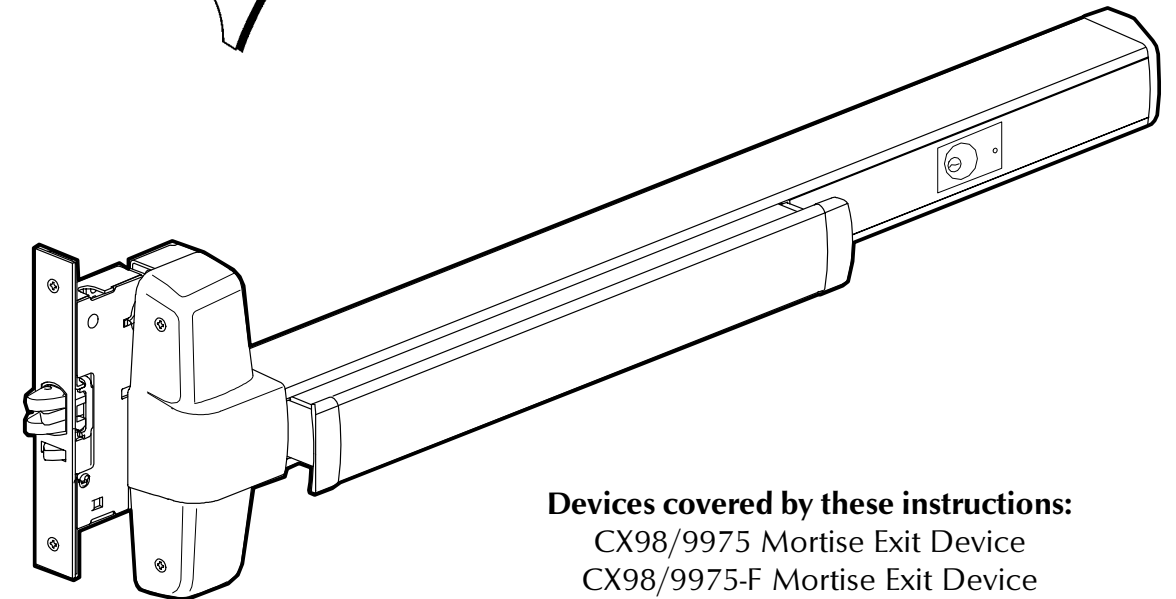

Devices covered by these instructions:

CX98/9975 Mortise Exit Device
CX98/9975-F Mortise Exit Device

Special tools needed:

#10-24 tap
Drill bits: #25, 1/8", 1/4",
5/16", 13/32"

Index:

• Screw chart	2
• Device installation	4-5
• Preparation chart	6
• CD (cylinder dogging)	7
• Cut device	8

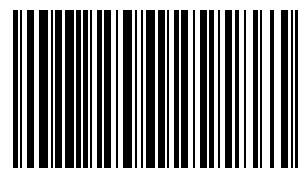

911384-00

This product is covered by the following patent numbers:

3,767,238	4,427,223
3,854,763	4,466,643
4,167,280	4,741,563

SCREW CHART

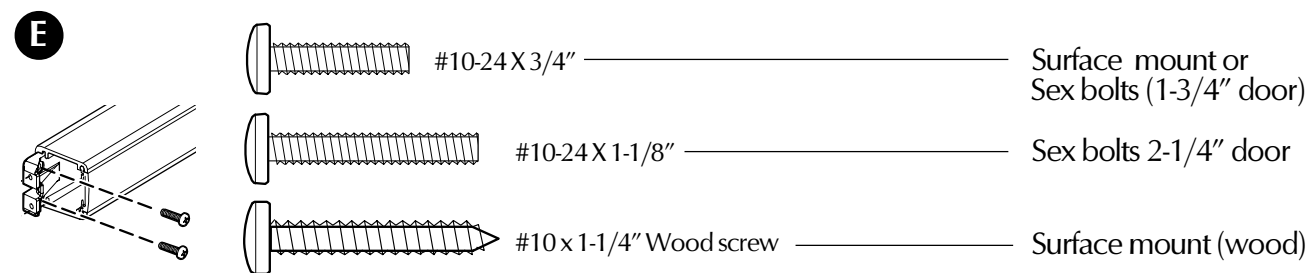
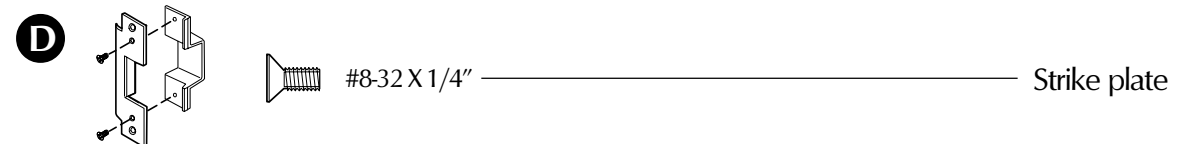
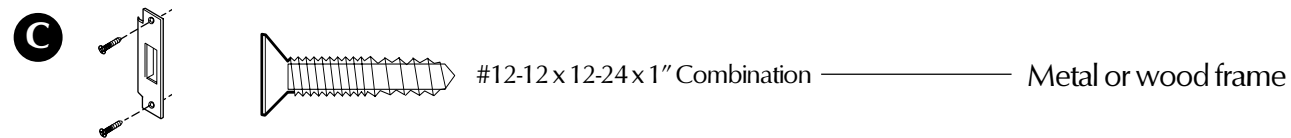
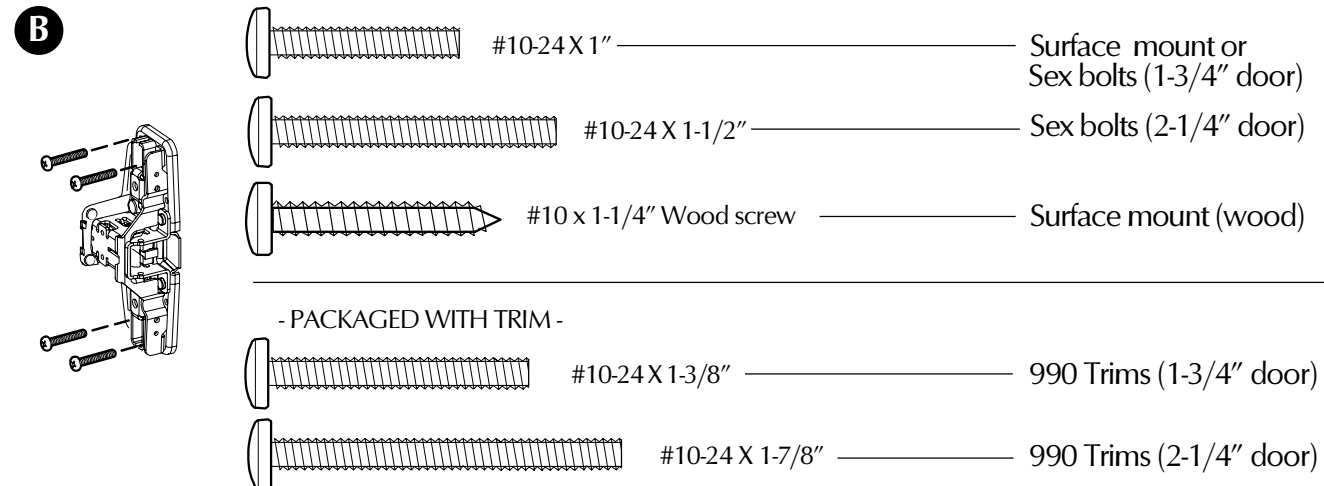
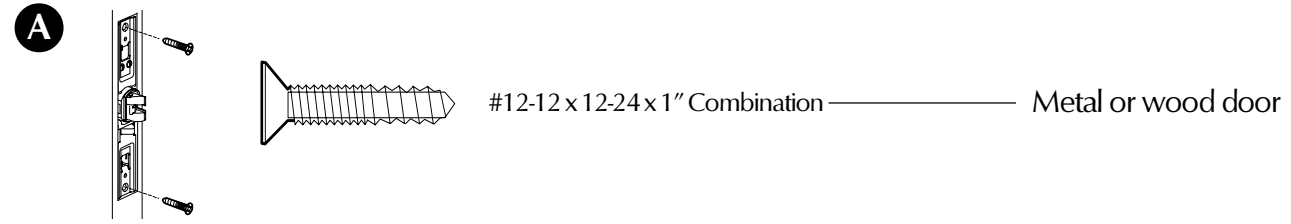

CD (CYLINDER DOGGING)

1. Make sure cylinder cam is positioned as shown with key removed. If not positioned as shown remove cylinder cam and reverse.

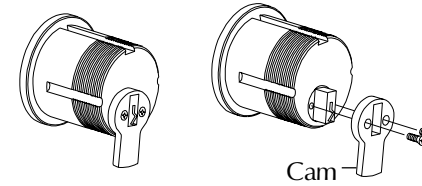

2. Remove center case cover from device.
3. Orient cylinder as shown at right and insert cylinder into bracket.
4. Tighten bracket set screw with a 1/16" hex wrench.
5. Secure cylinder bracket to center case.

To dog RHR device, depress pushbar, insert key, and turn key 180 degrees counterclockwise. **To dog LHR device**, turn key clockwise.

To undog RHR device, insert key and turn key 180 degrees clockwise. **To undog LHR device**, turn key counterclockwise.

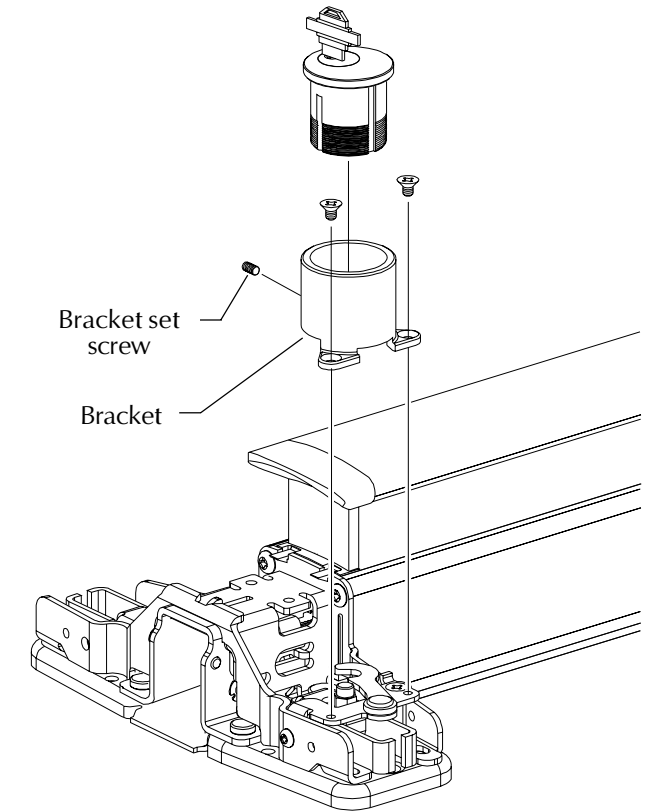

PREPARATION CHART

Go to instructions on page 4 before using Preparation Chart

Center case - 4 holes

Surface mount		Sex bolts or 990 trims	
Metal	#25 Drill #10-24 tap	Metal	1/4" Drill (device side) 13/32" Drill (trim side)
Wood	1/8" Drill pilot 1" deep	Wood	13/32" Drill thru

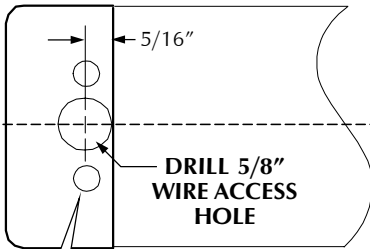

*End cap bracket - 2 holes

Surface mount		Sex bolts	
Metal	#25 Drill #10-24 tap	Metal	1/4" Drill (device side) 13/32" Drill (trim side)
Wood	1/8" Drill pilot 1" deep	Wood	13/32" Drill thru

Cut-out
For all 98/9975 devices

*Prepare end cap holes after lock side of device is mounted and hinge side of device is leveled

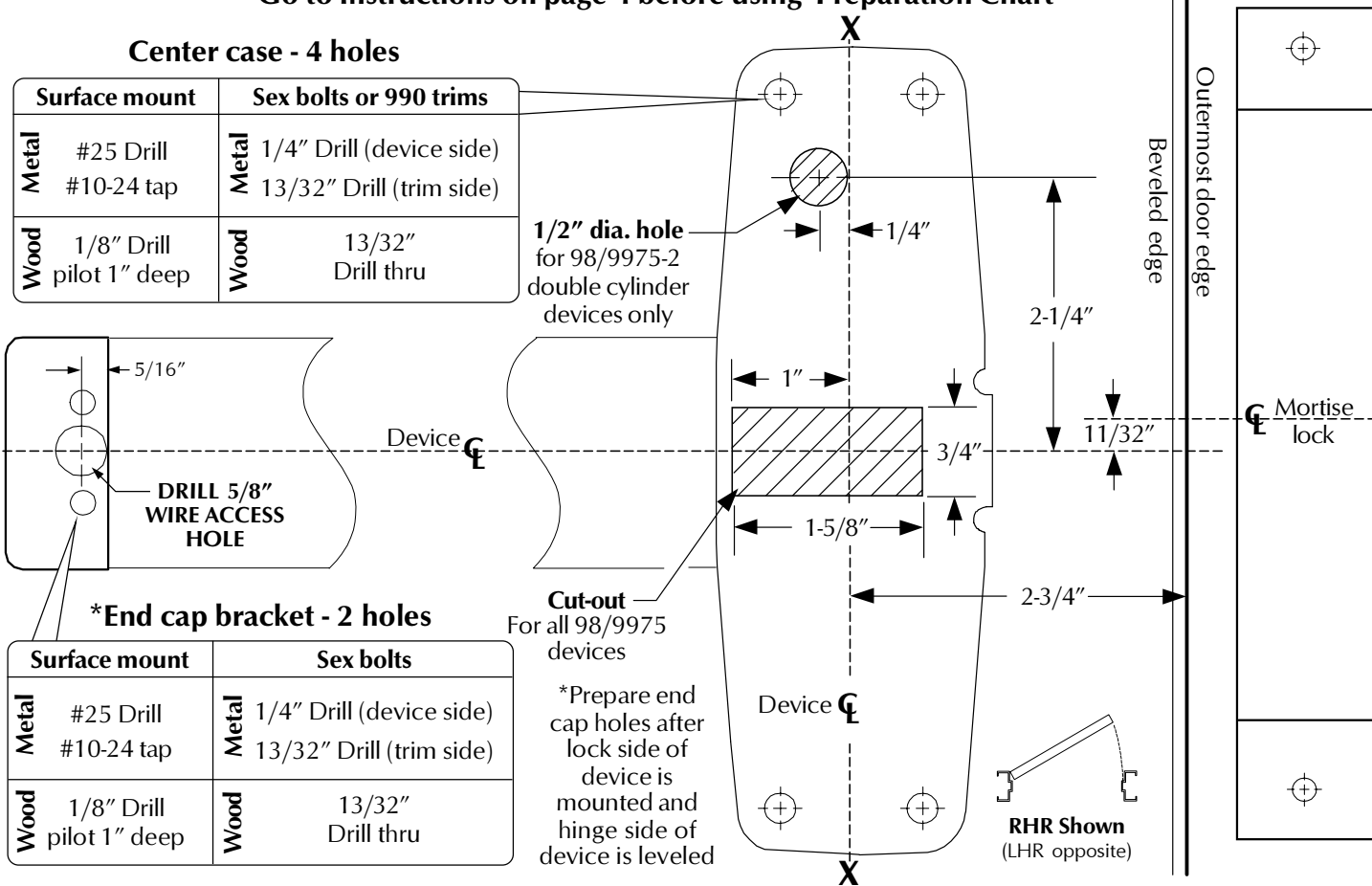

STRIKE PREPARATION

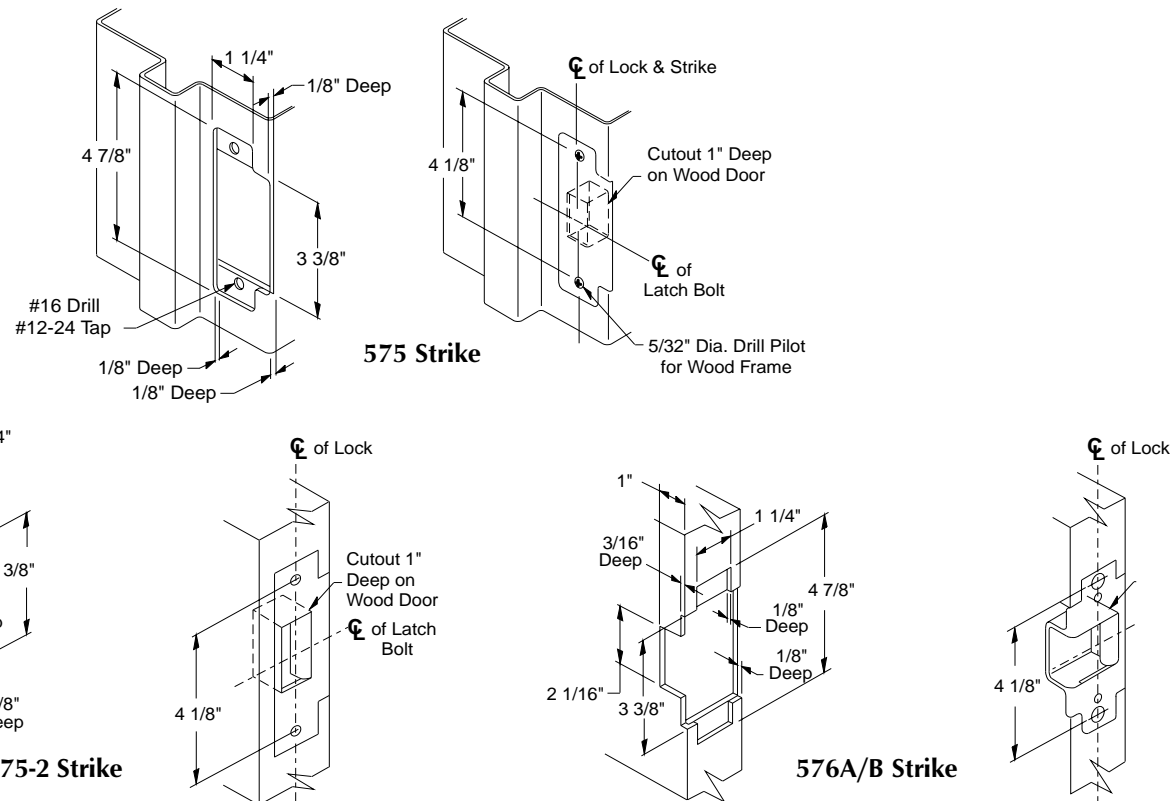

NOTE TO OWNER

⚠ WARNING

This product is not intended to detain or prevent exit, but to delay egress for not more than 15 seconds in accordance with NFPA 101 requirements for "special locking arrangements".

⚠ CAUTION

The signal switch inside the device is pre-set at the factory. Tampering with this switch can cause the basic exit features of this device to fail in an emergency.

ATTENTION!

There are no user serviceable parts in the electronic module or in the delay mechanism. Consult factory for repair of these components.

1. The electronic delay module is located in a separate box and must be installed by an electrician.
2. Check door size carefully before cutting device and cover. Refer to back page of instruction for dimensions.
3. Device should be tested periodically for proper function and moving parts should be lubricated semiannually.

****Give these instructions to building owner****

1

Draw horizontal device center line (C).

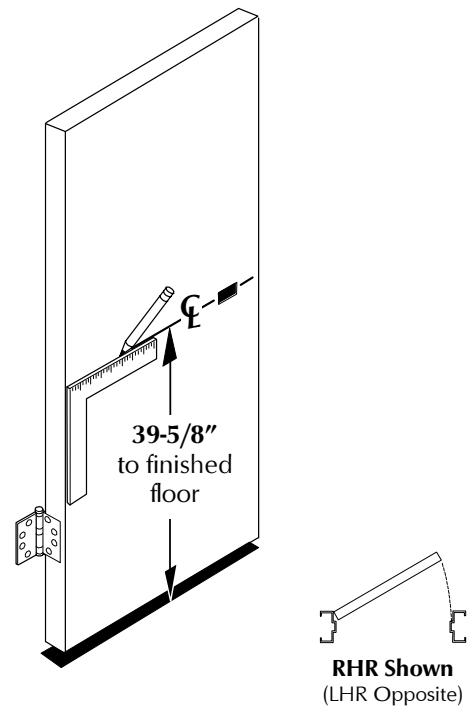

2

Align template along center line (C) and mark door.

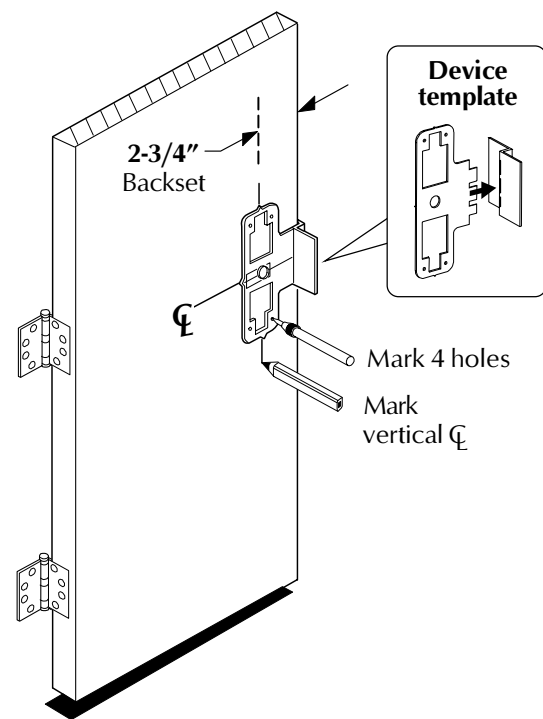

3

Prepare 4 center case holes and cutouts.

See "Preparation Chart" on page 6 for drill, tap, and cut-out information

See trim instructions for pull side door preparation.

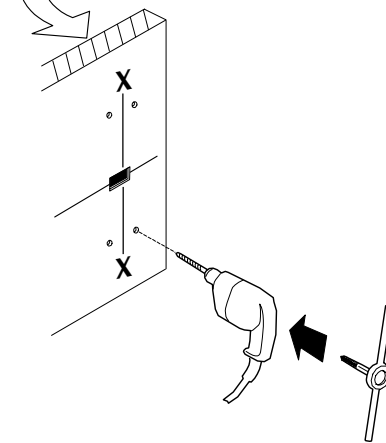

4

Install mortise lock into door.

See "#941019, 7500 mortise lock instructions"

With TP, K, and L trims with outside cylinder to lock and unlock trim function, turn this set screw all the way in

With EO, DT, NL, and "double cylinder" applications, screw remains as shipped

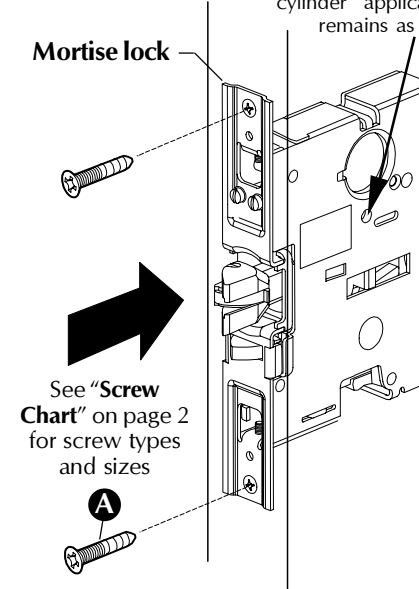

See "Screw Chart" on page 2 for screw types and sizes

5

Install trim (if using) and secure device center case to door.

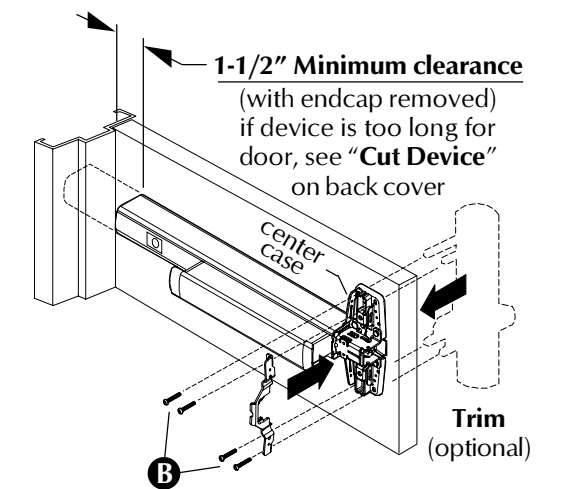

6

Install outside locking cylinder (if using) and finish installing mortise lock.

See 7500 Mortise Lock Instructions #941019

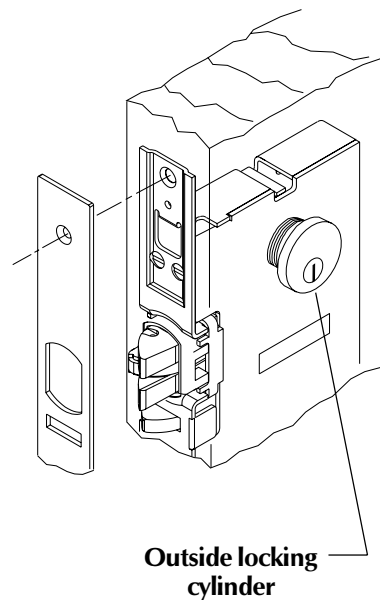

7

Install supplied strike to frame or other door.

See "Strike Preparation" on page 6 for preparation information

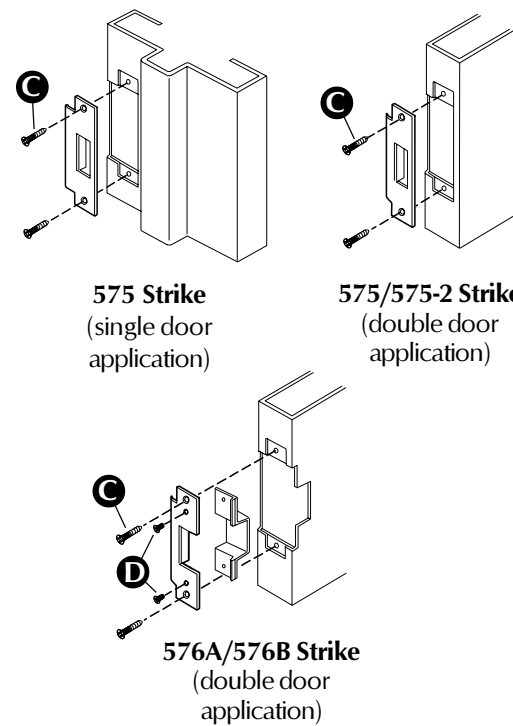

8

Install mounting bracket and end cap.

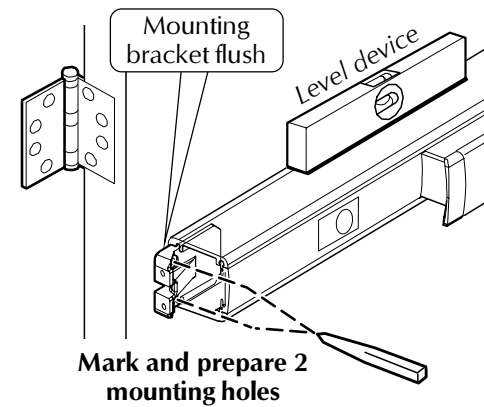

See "Preparation Chart" on page 6 for preparation information

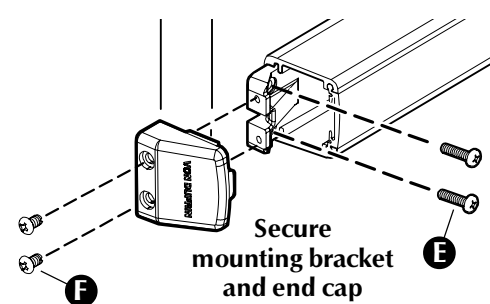

9

Adjust latch bolt.

Top view

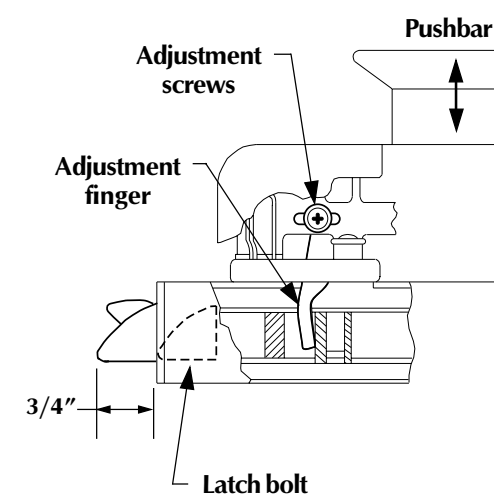

Loosen adjustment screws and adjust finger in or out until latchbolt is fully retracted (with pushbar down) and fully extended 3/4" (with pushbar up)

10

Install center case cover.

