

INSTALLATION INSTRUCTIONS:

1. Prepare door for exit device (see exit device instructions).
2. Prepare door for control:
 - A. Transfer center line from inside (exit device side) of door to outside (control side) of door. Use extra care if edge of door is beveled. Be sure center line is parallel to edge of door.
 - B. Locate and prepare holes as shown on other side.
3. Install rod member:
 - A. Slide rod member onto top rod (see Figure 1).
 - B. Install top rod connector (see exit device instructions).
 - C. Position rod member so it is visible in control side door cutout. Slightly tighten socket set screws to hold rod member in position.
 - D. Install and adjust top and bottom rod assemblies (see exit device instructions).
 - E. Adjust rod member so top surface is 1/8" above the center line of the thumbturn (Figure 2). Tighten rod member socket set screws.
4. Prepare control:
 - A. If necessary, change control cylinder plate for desired control function (Figure 3).
 - B. Install cylinder for 376-T or 376-T-NL control (Figure 4).
 - C. If necessary, move 1/4-20 x 1" socket set screws and mounting studs for handing of door (Figure 5).
5. Press exit device pushbar to retract latch bolts; install control.
6. Test key, control, and exit device action.

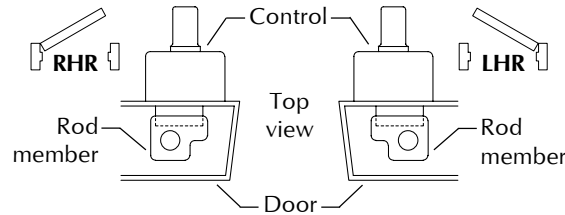

Figure 1. Rod member position for door handing.

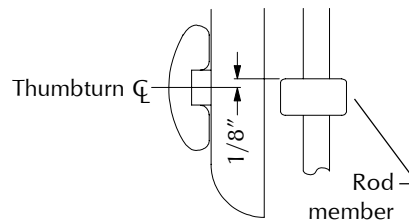

Figure 2. Rod member adjustment.

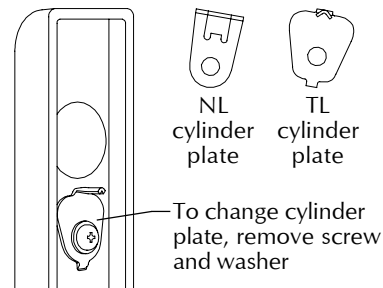

Figure 3. NL and TL function cylinder plates.

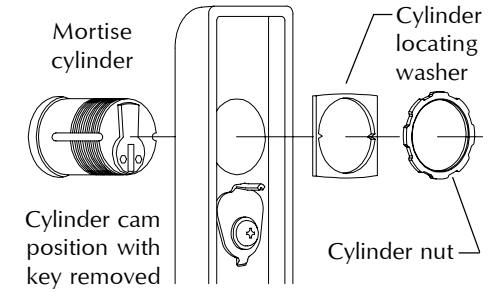

Figure 4. Cylinder installation.

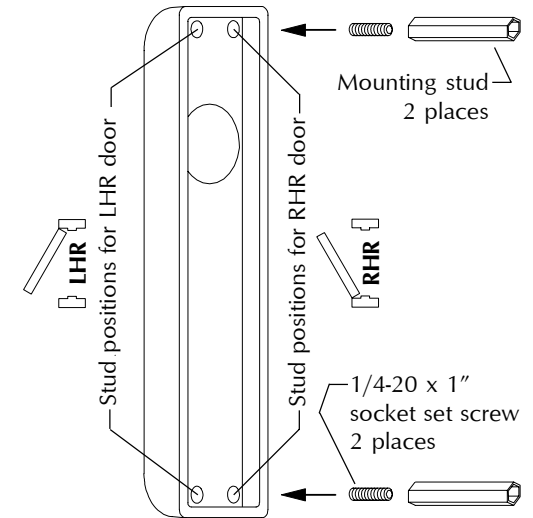
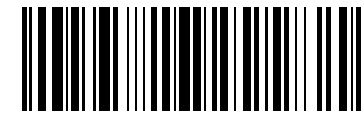

Figure 5. Mounting stud positions.



941114-00

Device Application Schedule
3347/3547 Vertical Rod Device
3347-F/3547-F Vertical Rod Device
3347A/3547A Vertical Rod Device
3347A-F/3547A-F Vertical Rod Device
5547 Vertical Rod Device
98/9947 Vertical Rod Device
98/9947-F Vertical Rod Device

Do not use this control with 3347/3547 or 3347A/3547A devices with 1-1/16" latch case backset on bullnose edge doors with weather strip channel.

DESCRIPTION:

376-T, 376-T-NL, AND 376-T-BE CONTROL FOR METAL DOOR APPLICATIONS

Copyright © 2006 Ingersoll-Rand Company Limited



DIRECTION NUMBER:
941114_00(14)

SHEET#:
1 of 2

DATE:
04/07/2006

VON DUPRIN®

Outside
Inside
LHR shown
RHR opposite

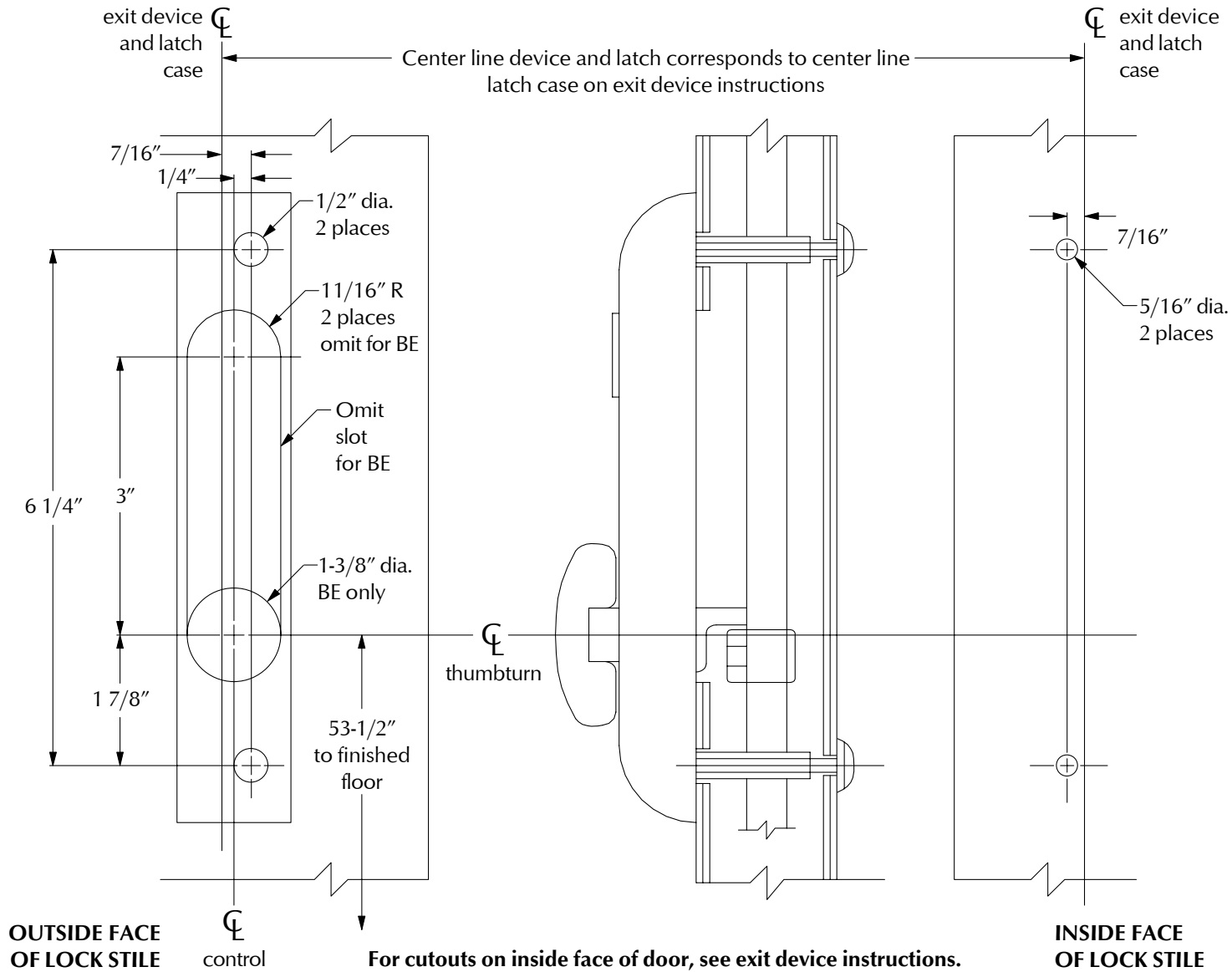

DESCRIPTION:

376-T, 376-T-NL, AND 376-T-BE CONTROL FOR METAL DOOR APPLICATIONS

Copyright © 2006 Ingersoll-Rand Company Limited



DIRECTION NUMBER:
941114_00(14)

SHEET#:
2 of 2

DATE:
04/07/2006

VON DUPRIN®