

VON DUPRIN®

INSTALLATION INSTRUCTIONS

1. Prepare door for exit device. See exit device instructions for holes, backset (line X-X), and center lines.
2. Prepare door for trim:
 - A. Transfer line X-X from inside (exit device) side of door to outside (trim side) of door. Use extra care if edge of door is beveled. Be sure line X-X is parallel to edge of door.
 - B. Locate and prepare all holes as shown.
3. Change handing if necessary (see other side).
4. For L function trim only, turn mortise lock function screw all the way in (Figure 1).
5. Install mortise lock.
6. Install exit device and trim. Use 1-3/8" screws for 1-3/4" doors, 1-7/8" screws for 2" and 2-1/4" doors (cut down screws for 2" door if necessary).
7. For L function trim only, install mortise cylinder (Figure 2).

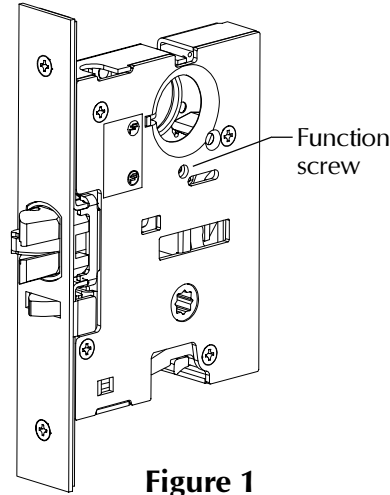

Figure 1

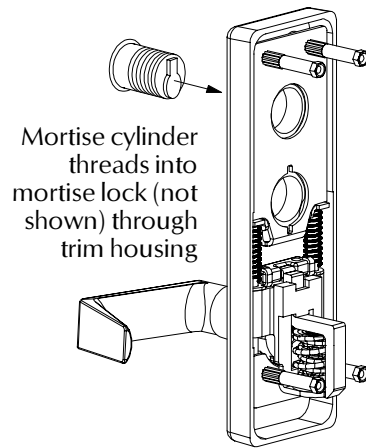
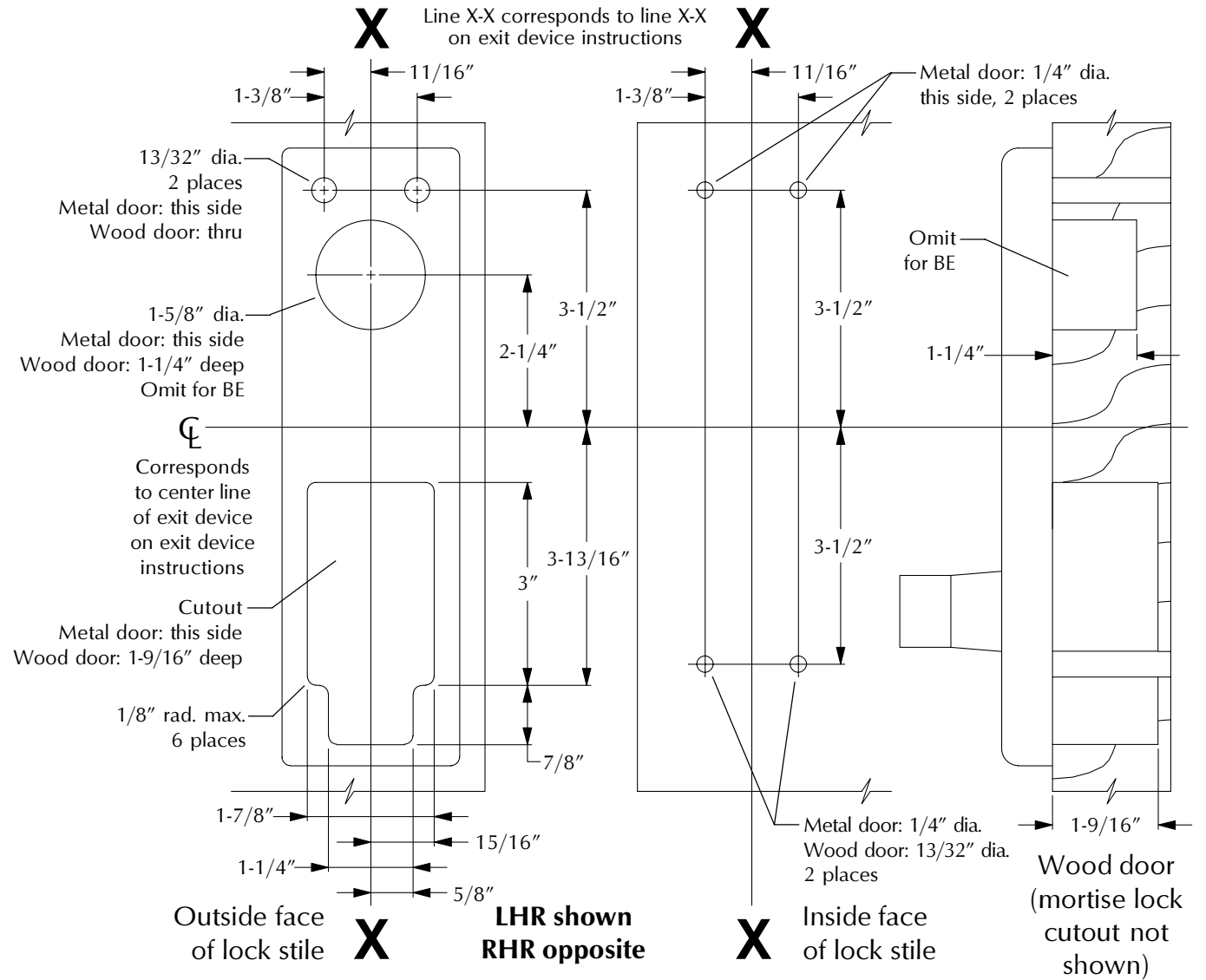

Figure 2



For cutouts on inside face of door, see exit device instructions

Device Application
Schedule (Panic and Fire)
98/9975 Mortise Lock Device

IR Security & Safety
Proven Source. Proven Solutions.™



994/996L/L-BE BREAKAWAY™ TRIM
FOR MORTISE LOCK DEVICE

Copyright © 2004 Ingersoll-Rand.
All rights reserved.

PAGE NO.
1 of 2

REVISION
3



921006-00

VON DUPRIN®

TO CHANGE LEVER HANDING



CAUTION

Do not remove springs from slider.



IMPORTANT

In Step 3, make sure to keep loose components on guide post assembly.

1. Remove four mounting studs.

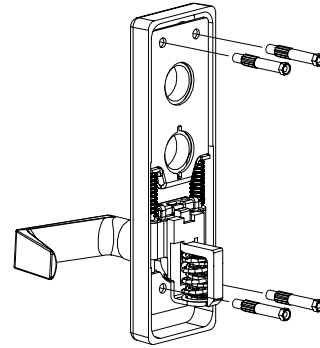

2. Remove endplate from under slider.

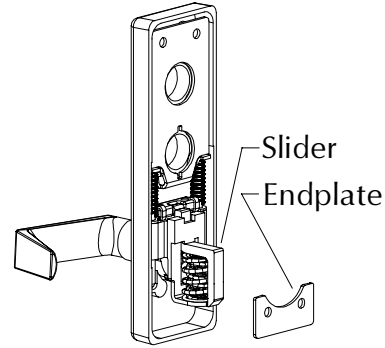

3. Push up on slider and pivot out to remove guide post assembly.

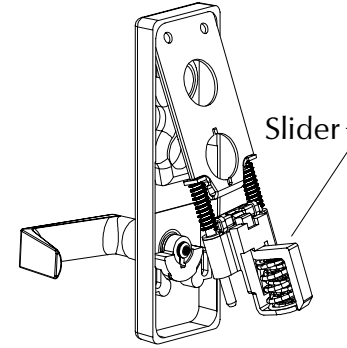

4. Use retaining pliers to remove retaining ring. Remove cam.

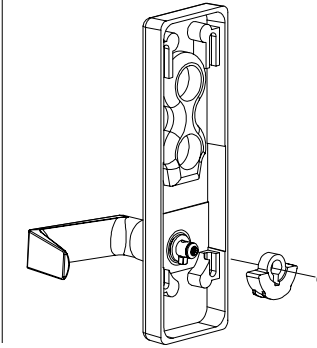

5. Use 3/32" hex wrench to loosen set screw. Remove shear pin.

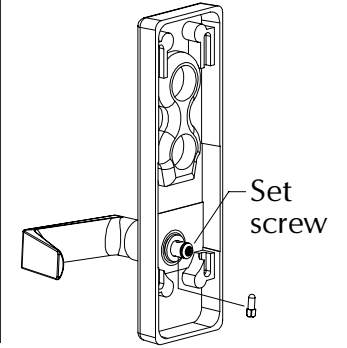

6. Remove spacer.

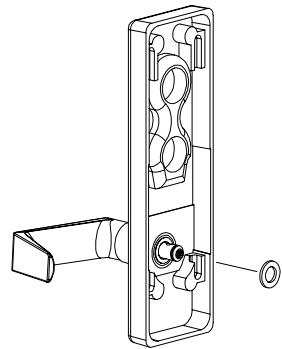

7. Place lever in RHR or LHR position.

RHR

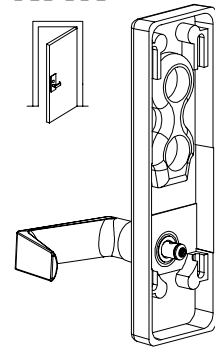

LHR

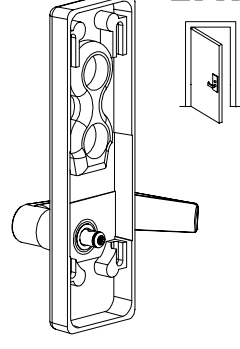

8. Re-install spacer (see Step 6).

9. Re-install shear pin with head pointed down (see Step 5).

10. Pull lever outwards to align shear pin head with spacer.

11. Re-install cam with "L" visible for LHR or "R" visible for RHR (see Step 4), then tighten set screw (see Step 5).

RHR

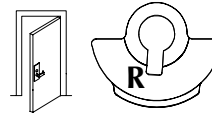

LHR



12. Re-install retaining ring (see Step 4).

13. Make sure lever is in horizontal position, then re-install guide post assembly.

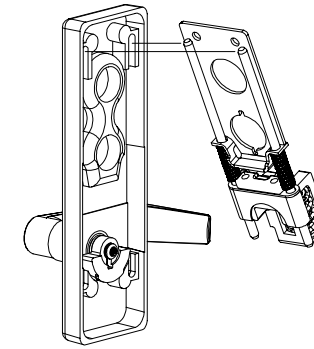

Tilt guide post assembly and insert tops of rods into slots

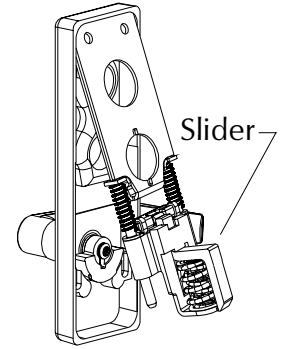

Push up on slider and pivot assembly in

14. Re-install end plate (see Step 2) and four mounting studs (see Step 1). **Do not over-tighten studs.**



NOTE

Lever cannot be broken down unless trim is mounted on door and device is locked.

IR Security & Safety
Proven Source. Proven Solutions.™



994/996L/L-BE BREAKAWAY™ TRIM
FOR MORTISE LOCK DEVICE

Copyright © 2004 Ingersoll-Rand.
All rights reserved.

PAGE NO.
2 of 2

REVISION
3

921006-00