

VON DUPRIN®

Installation Instructions

Note: Use lock washers on top and bottom mullion fittings except for counter sunk screws.

1. Line up bottom mullion fitting with center of door opening and flush with closed doors (Figure 1 or 2) and install.
2. Line up top mullion fitting with center of door opening and flush with closed doors as shown in Figure 3 and install. See Figures 6, 7, and 8 on reverse side for optional frame conditions.
3. Cut mullion body to length as shown in Figure 4.
4. Insert mullion in top fitting and slide bottom of mullion into place in bottom fitting (see Figure 9 on reverse side).
5. Secure bottom set screw.
6. Raise top mullion clamp over top mullion fitting and secure with mounting screws (see Figure 9 on reverse side).
7. Apply stabilizer block to door as shown in Figure 5.
8. Adjust strikes for $1/32''$ clearance between latchbolt and strike (see Figure 9 on reverse side).

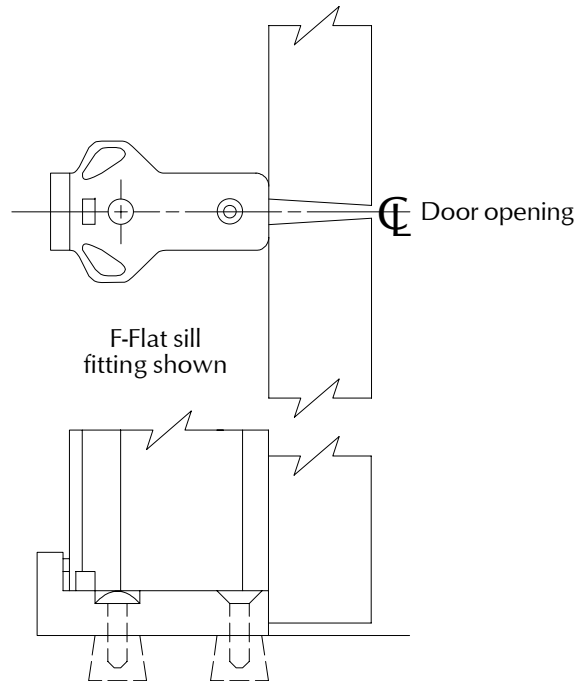

Figure 1

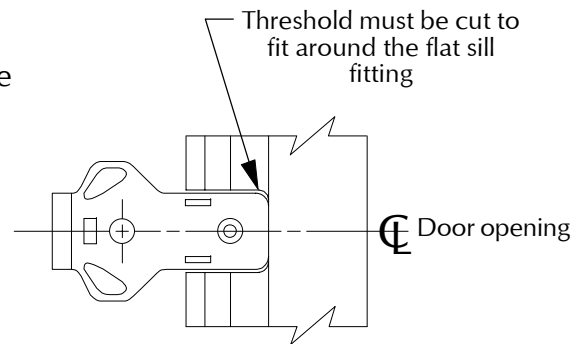

Figure 2

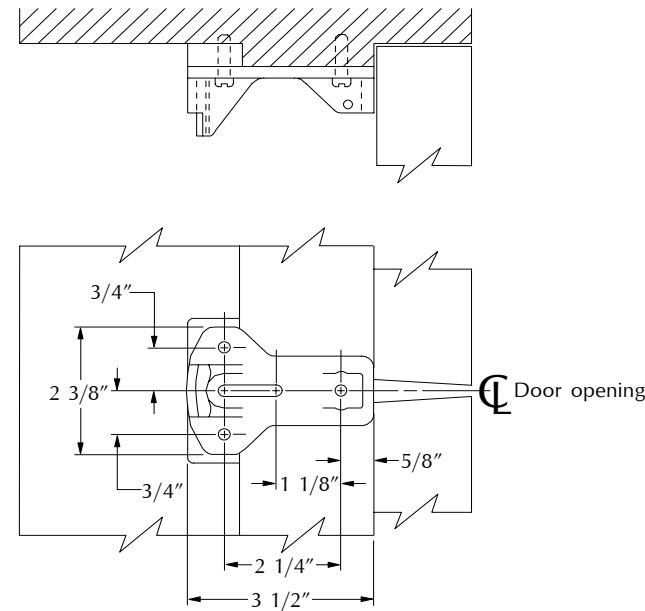

Figure 3

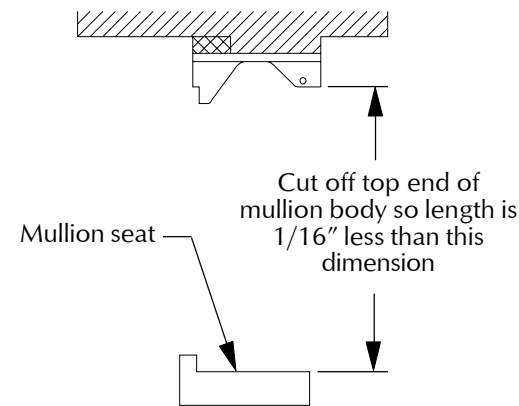

Figure 4

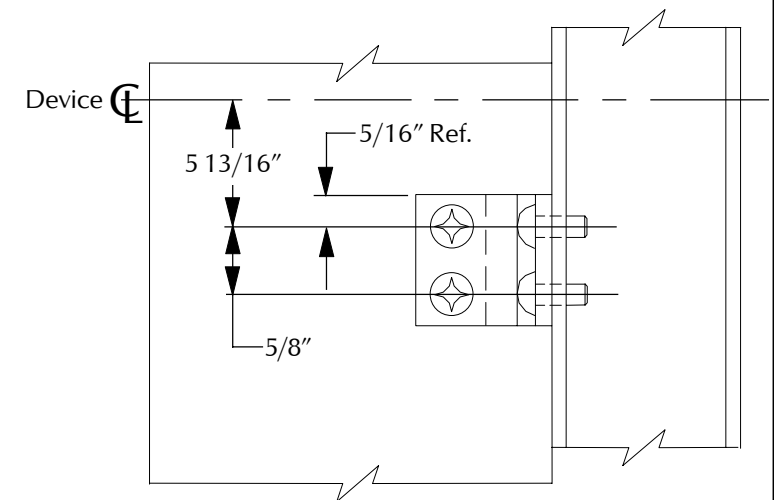
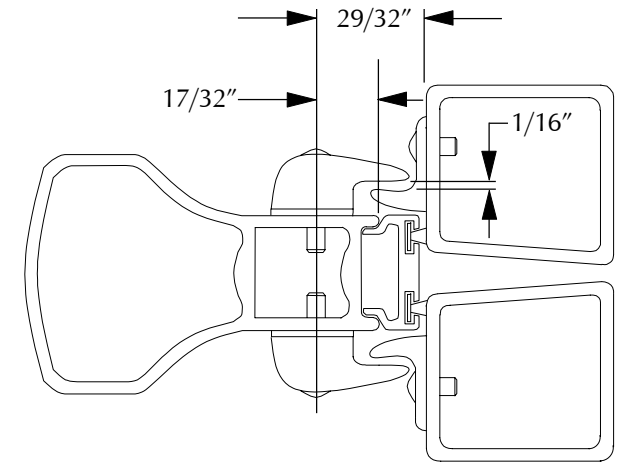

Figure 5



5654 REMOVABLE MULLION

For cutouts on inside face of door, see directions in device carton.

© 2006 Ingersoll-Rand
Company Limited

PAGE NO.
1 of 2

REVISION
9

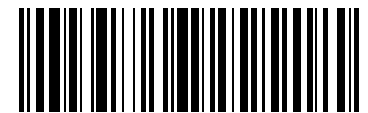

941031-00

VON DUPRIN®

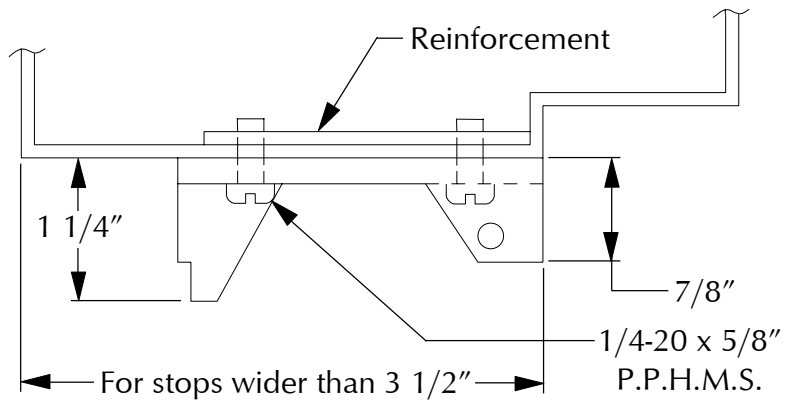

Figure 6

NOTE
Reinforcement for all sheet metal frames is to be supplied by frame mfg.

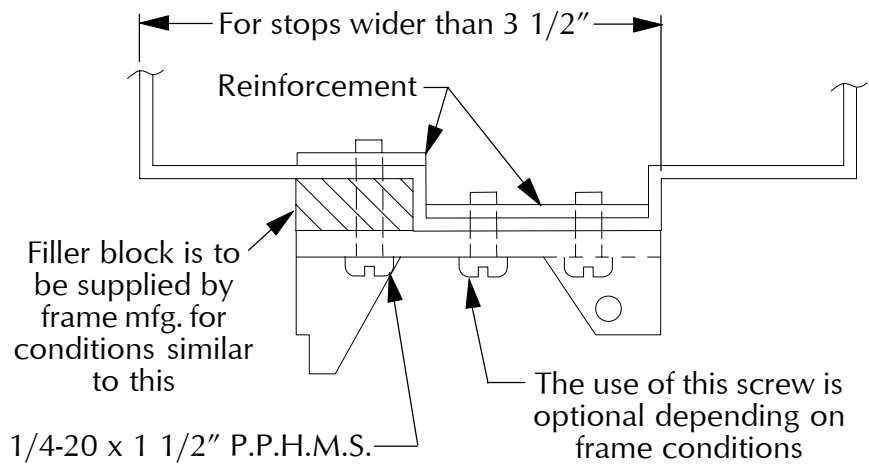

Figure 7

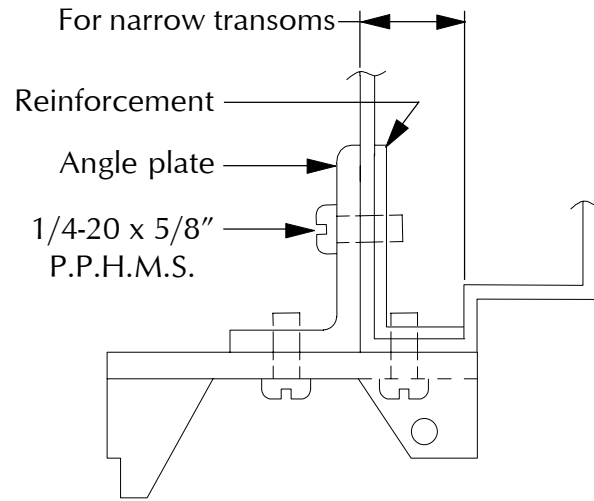
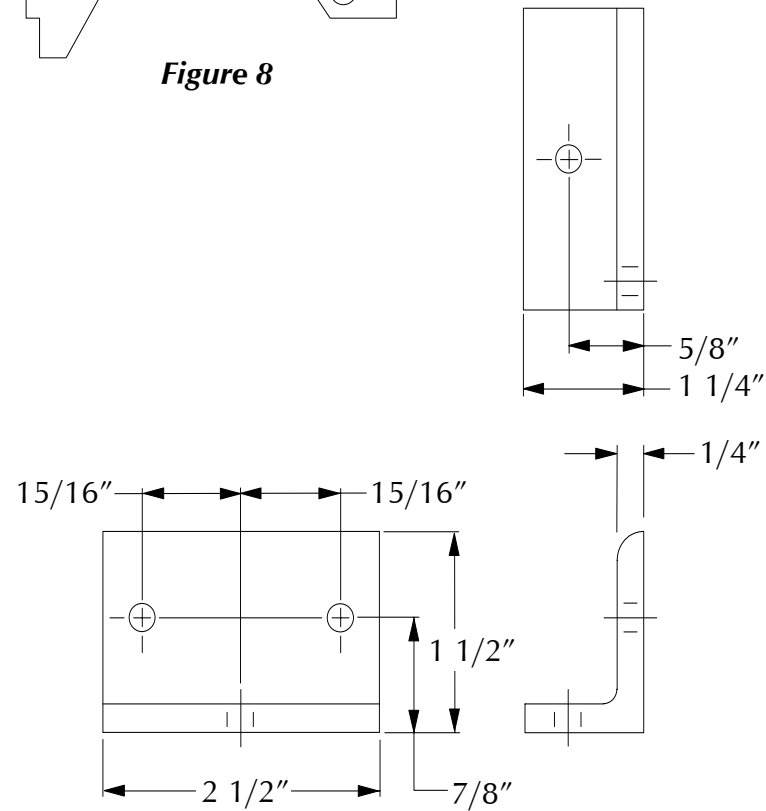
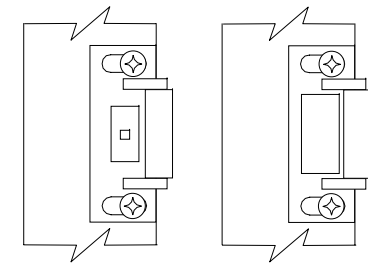
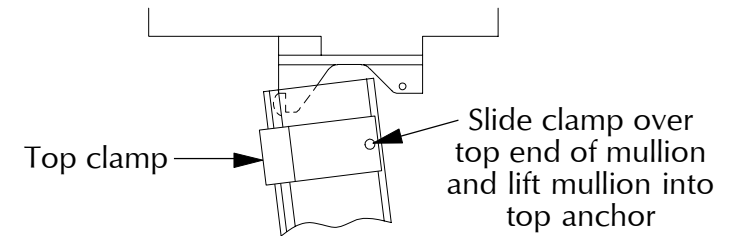

Figure 8



Adj. Angle Plate



299 Strike
(2 required)
All standard rim devices

264 Strike
(2 required)
All standard rim devices

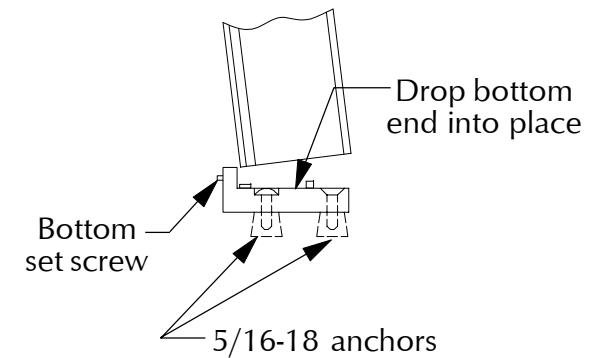

Figure 9